

EU Declaration of Conformity

According to
EMC Directive 2004/108/EC

For the following

Product : PoE Switch
Model Name : DH-2010P

Manufactured at : IDIS CO., LTD.
Address : 8-10, TECHNO 3-RO,
YUSEONG-GU, DAEJEON, KOREA

We hereby declare, Electromagnetic Compatibility Directives (2004/108/EC) are fulfilled, as laid out in the guideline set down by the member states of the EEC Commission. This declaration is valid for all samples that are part of this declaration, which are manufactured according to the production charts appendix.

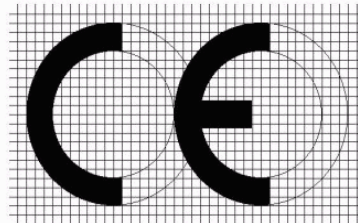

The standards relevant for the evaluation of EMC requirements are as follows:

Test Standards : ETSI EN 300 386 V 1.6.1 (2012-04)
(Other than Telecommunication Centers (OTC))
EN 61000-3-2:2006+A1:2009+A2:2009
EN 61000-3-3:2008

Date of issue: May 27, 2014

IDIS CO., LTD.

8-10, TECHNO 3-RO,
YUSEONG-GU, DAEJEON, KOREA

(Name and signature of authorized person)

EMC TEST REPORT

Test report No : EMC-CE-4913
Type of Equipment : PoE Switch
Model Name : DH-2010P
Applicant : IDIS CO., LTD.
8-10, TECHNO 3-RO,
YUSEONG-GU, DAEJEON, KOREA
Manufacturer : IDIS CO., LTD.
8-10, TECHNO 3-RO,
YUSEONG-GU, DAEJEON, KOREA
Test standards : ETSI EN 300 386 V 1.6.1 (2012-04)
(Other than Telecommunication Centers (OTC))
EN 61000-3-2:2006+A1:2009+A2:2009
EN 61000-3-3:2008
Testing Laboratory : EMC Compliance Ltd.
Test result : Complied

The results in this report apply only to the sample tested. This test report shall not be reproduced except in full, without the written Approval of EMC compliance Laboratory.

Date of receipt: 2014. 04. 23

Date of testing: 2014. 05. 07 ~ 05. 12

Issued date: 2014. 05. 27

Tested by:

BEAK, JEONG-SOO

Approved by:

YEOM, HAN-SEOK

Contents

1. Applicant information	3
2. Laboratory information	4
3. Test system configuration.....	5
3.1 Operation environment	5
3.2 Measurement Uncertainty	6
4. Description of E.U.T.	7
4.1 General information	7
4.2 Product description	8
4.3 Auxiliary equipments	8
4.4 Test configuration	9
4.5 Operating conditions	10
5. Summary of test results	11
5.1 Standards & results	11
5.2 Performance criteria	12
6. Test results	14
6.1 Conducted Emission	14
6.2 Radiated Emission	23
6.3 Harmonics	29
6.4 Flicker	34
6.5 Electrostatic Discharge	37
6.6 Radio Frequency Electromagnetic Fields	41
6.7 Electric Fast Transient/BURST	44
6.8 Surge	47
6.9 Conducted Immunity	50
6.10 Dips and Interruptions	53
7. E.U.T. photographs.....	57

1. Applicant information

Applicant: IDIS CO., LTD.
Address: 8-10, TECHNO 3-RO,
YUSEONG-GU, DAEJEON, KOREA
Telephone: +82-31-723-5205
Fax: +82-31-723-5108
E-mail: jjungdoo@idis.co.kr
Contact name: **Jang Jung Doo**

Manufacturer: IDIS CO., LTD.
Address: 8-10, TECHNO 3-RO,
YUSEONG-GU, DAEJEON, KOREA
Telephone: +82-31-723-5205
Fax: +82-31-723-5108
E-mail: jjungdoo@idis.co.kr
Contact name: **Jang Jung Doo**

2. Laboratory information

Address

EMC compliance Ltd.

65, Sinwon-ro, Yeongtong-gu, Suwon-si, Gyeonggi-do, 443-390, Korea

Telephone Number: 82 31 336 9919

Facsimile Number: 82 505 299 8311

FCC CAB.: KR0040

VCCI Registration No. : R-3327, G-198, C-3706, T-1849

Industry Canada Registration No. : 8035A

KOLAS NO.: 231

SITE MAP

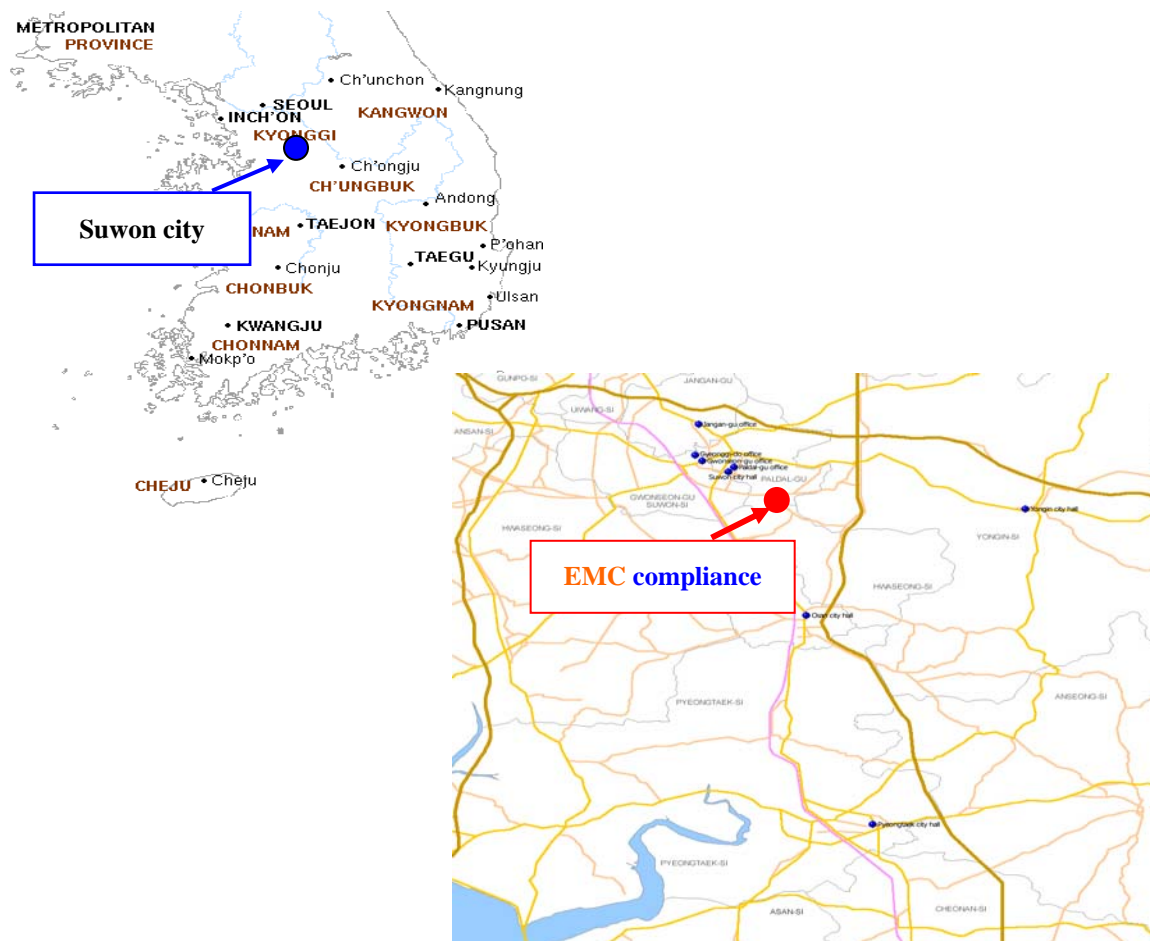

3. Test system configuration

3.1 Operation environment

	Temperature	Humidity	Pressure
Chamber(10 m)	: 20.6 °C	36.9 % R.H.	-
Shielded room(CE)	: 22.0 °C	46.8 % R.H.	-
Shielded room(ESD)	: 24.6 °C	40.2 % R.H.	100.4 kPa

Test site

These testing items were performed following locations;

Test item	Test site
Conducted Emission	Shielded Room
Radiated Emission	10 m Chamber
Harmonics current	Immunity area
Voltage fluctuations and flickers	Immunity area
Electrostatic discharge	Shielded Room
Radiated RF immunity	Fully anechoic chamber (3 m)
Electric Fast Transient/BURST	Shielded Room
Surge	Shielded Room
Conducted RF immunity	Shielded Room
Magnetic field immunity	Shielded Room
Voltage dip/interruption	Shielded Room

3.2 Measurement Uncertainty

All measurements involve certain levels of uncertainties, especially in field of EMC.

The factors contributing to uncertainties are test receiver, cable loss, antenna factor calibration, Antenna directivity, antenna factor variation with height, antenna phase center variation, antenna frequency interpolation, measurement distance variation, site imperfection, mismatch, and system repeatability.

Based on CISPR 16-4-2, the measurement uncertainty level with a 95 % confidence level was applied.

Conducted emission measurement (C.L: Approx 95 %, k = 2)		
Shielded Room (CE#1)	9 kHz ~ 150 kHz: ± 3.82 dB 150 kHz ~ 30 MHz: ± 3.43 dB	
Shielded Room (CE#2)	9 kHz ~ 150 kHz: ± 3.82 dB 150 kHz ~ 30 MHz: ± 3.43 dB	
Shielded Room (CE#3)	9 kHz ~ 150 kHz: ± 4.00 dB 150 kHz ~ 30 MHz: ± 3.63 dB	
Radiated Emission measurement (C.L: Approx 95 %, k = 2)		
10 m Chamber (#F4)	30 MHz ~ 300 MHz	3 m: + 4.56 dB, - 4.58 dB 10 m: + 4.56 dB, - 4.56 dB
	300 MHz ~ 1 000 MHz	3 m: + 4.84 dB, - 4.85 dB 10 m: + 4.71 dB, - 4.72 dB
	1 GHz ~ 6 GHz	3 m: + 6.19 dB, - 6.20 dB
10 m Chamber (#F2)	30 MHz ~ 300 MHz	3 m: + 4.86 dB, - 4.88 dB 10 m: + 4.86 dB, - 4.86 dB
	300 MHz ~ 1 000 MHz	3 m: + 4.98 dB, - 4.99 dB 10 m: + 4.85 dB, - 4.87 dB
	1 GHz ~ 6 GHz	3 m: + 6.19 dB, - 6.20 dB
Radio Frequency Electromagnetic Fields (C.L: Approx 95 %, k = 2)		
± 1.82 dB		
Disturbance power Electromagnetic Fields (C.L: Approx 95 %, k = 2)		
± 3.73 dB		

4. Description of E.U.T.

4.1 General information

Model		DH-2010P	DH-2018P
CPU		Embedded MIPS	
System Memory		256MB SDRAM, 32M Flash	
Copper Service Port		8 RJ-45 Connectors (10/100BASE-T)	16 RJ-45 Connectors (10/100BASE-T)
Copper Uplink Port		2 RJ-45 Connectors (10/100/1000BASE-T)	
Rated Input		AC100-240V, 50/60Hz	AC100-240V, 50/60Hz
Power Consumption		Max. 75W	Max. 150W
PSE Power		Max. 70W	Max. 140W
PoE-supported Standards		IEEE 802.3af-2003 and IEEE 802.3at-2009	
PoE-supported Network Camera Connection		Up to 8 IEEE 802.3af cameras or 2 IEEE 802.3at cameras	Up to 16 IEEE 802.3af cameras or 4 IEEE802.3at cameras
Environmental Conditions	Operating Temperature	0°C - 40°C (32°F - 104°F)	
	Operating Humidity	10 ~ 90%	
	Storage Temperature	30°C - 60°C (-22°F - 140°F)	
Dimensions (W1 x H x D)		280mm x 44mm x 180mm (11.02" x 1.73" x 7.09")	430mm x 44mm x 180mm (16.93" x 1.73" x 7.09")
Weight (Main Unit)		1.35Kg (2.98 lbs.)	2.05Kg (4.52 lbs.)
Weight (Packaging)		1.9Kg (4.19 lbs.)	2.9Kg (6.39 lbs.)
Electrical Approvals		FCC, UL, CE, CB, KC	
IEEE Standards		IEEE 802.3 10BASE-T [1], IEEE 802.3u 100BASE-TX [2], IEEE 802.3ab 1000BASE-T, IEEE 802.3ad Link Aggregation, IEEE 802.3x Flow Control Support, IEEE 802.1p Priority Support, IEEE 802.1D (Bridging) 1993, IEEE 802.1w Rapid Spanning Tree	
Internet Standards		RFC 3635 Ethernet-like MIB, RFC2863 Interface Group MIB , RFC 2819 RMON, RFC 1493 Bridge MIB, RFC 2674 Bridge MIB extension	

4.2 Product description

Type of product	PoE Switch
Model name (Basic)	DH-2010P
Model name (Variant)	-
Difference	-
Brand name	-
Trade name	-
Serial no	Engineering Sample
Testing voltage	230 V , 50 Hz
Product rating	AC 100 - 240 V , 50 / 60 Hz
Internal clock frequency	Above 108 Mhz
Note	-

4.3 Auxiliary equipments

*EMI Test

Type	Model / Part #	Serial number	Manufacturer
CCTV Camera	-	-	IDIS
Note PC	ProBook 4540S	-	HP
USB Mouse	1088	816594870512265	Microsoft
Headset	SHS-250V	-	SAMSUNG

*EMS Test

Type	Model / Part #	Serial number	Manufacturer
Note PC	ProBook 4540S	-	HP
Smart bits	SMB-600	-	Spirent

4.4 Test configuration

* EMI Test

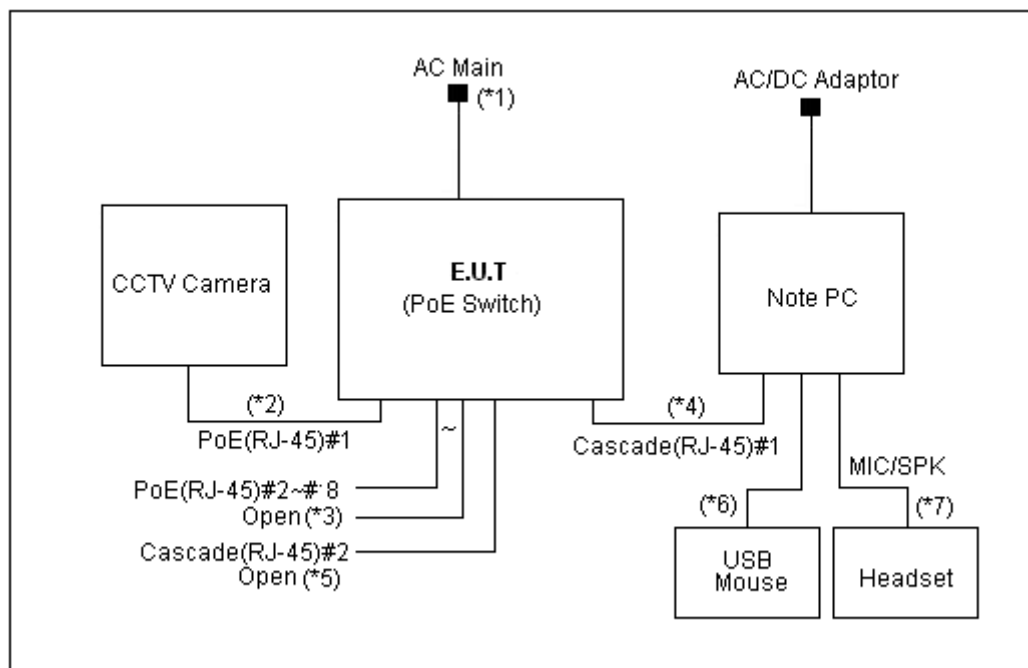

Note	Start		End		Cable	
	Name	I/O port	Name	I/O port	Length (m)	Spec.
1	EUT (PoE Switch)	Power	AC main	Power	2.0	Non-Shield
2		PoE(RJ-45)#1	CCTV Camera	PoE(RJ-45)	3.0	Non-Shield
3		PoE(RJ-45)#2~#8	Open	-	1.0	Non-Shield
4		Cascade(RJ-45)#1	Note PC	Cascade(RJ-45)	3.0	Non-Shield
5		Cascade(RJ-45)#2	Open	-	1.0	Non-Shield
6	Note PC	USB	USB Mouse	USB	1.8	Shield
7		MIC/SPK	Headset	MIC/SPK	2.0	Non-Shield

*** EMS Test**

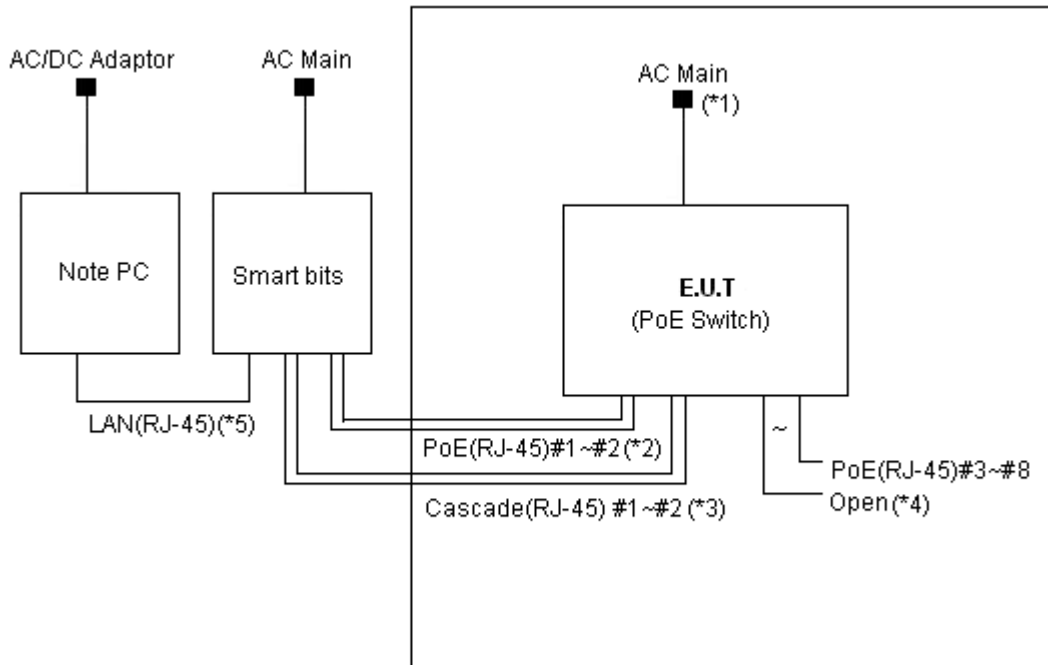

Note	Start		End		Cable	
	Name	I/O port	Name	I/O port	Length (m)	Spec.
1	EUT (PoE Switch)	Power	AC main	Power	2.0	Non-Shield
2		PoE(RJ-45)#1~#2	Smart bits	PoE(RJ-45)#1~#2	5.0	Non-Shield
3		Cascade(RJ-45) #1~#2	Smart bits	Cascade(RJ-45) #1~#2	5.0	Non-Shield
4		PoE(RJ-45)#3~#8	Open	-	1.0	Non-Shield
5	Note PC	LAN(RJ-45)	Smart bits	LAN(RJ-45)	1.0	Non-Shield

4.5 Operating conditions

The EUT was configured as normal intended use.

Test mode	Normal operating
EMI	Camera Web View Test
	Ping test.
EMS	During the test, by running smart bits program, the EUT was monitored for packet data rate check.

5. Summary of test results

5.1 Standards & results

The following standards have been applied:

ETSI EN 300 386 V 1.6.1 (2012-04)

Electromagnetic compatibility and Radio spectrum Matters (ERM);

Telecommunication network equipment; Electromagnetic Compatibility (EMC) requirements

Test items Result

Basic Standard	Description	Test Result
ETSI EN 300 386 V 1.6.1 (2012)	Electromagnetic compatibility and Radio spectrum Matters (ERM);Telecommunication network equipment; Electromagnetic Compatibility (EMC) requirements	<input checked="" type="checkbox"/> Pass <input type="checkbox"/> Fail
ETSI EN 300 386 clause 6.4	Radiated emission For radiated emission in the frequency range 30 MHz to 1 000 MHz the test method specified in the EN 55022 [4] shall apply. For radiated emission in the frequency range 1 000 MHz to 6 000 MHz the test method and the conditional testing Procedure specified in the EN 55022 [4] shall apply.	<input checked="" type="checkbox"/> Pass <input type="checkbox"/> Fail
ETSI EN 300 386 clause 6.1	Conducted emissions The limits defined in the EN 55022 [4] shall apply.	<input checked="" type="checkbox"/> Pass <input type="checkbox"/> Fail
ETSI EN 300 386 clause 6.3	For conducted emissions on telecommunications ports in the frequency range 0,15 MHz to 30 MHz, the test method specified in EN 55022 [4] shall apply.	<input checked="" type="checkbox"/> Pass <input type="checkbox"/> Fail
ETSI EN 300 386 clause 6.1	Current harmonics For current harmonics emission the test methods of either EN 61000-3-2 [5] or EN 61000-3-12 [8] shall apply.	<input checked="" type="checkbox"/> Pass <input type="checkbox"/> Fail
ETSI EN 300 386 clause 6.1	Voltage fluctuations (Flickers) For voltage fluctuations (Flickers) the test methods of either EN 61000-3-3 [6] or EN 61000-3-11 [7] shall apply.	<input checked="" type="checkbox"/> Pass <input type="checkbox"/> Fail
ETSI EN 300 386 clause 7.2.2.1.1	Electrostatic discharge	<input checked="" type="checkbox"/> Pass <input type="checkbox"/> Fail
ETSI EN 300 386 clause 7.2.2.1.2	Radio frequency electromagnetic field amplitude modulated.	<input checked="" type="checkbox"/> Pass <input type="checkbox"/> Fail
ETSI EN 300 386 clause 7.2.2.4.1 / clause 7.2.2.2.1 / clause 7.2.2.3.1	Fast transients. / Telecommunications port for indoor signal lines	<input checked="" type="checkbox"/> Pass <input type="checkbox"/> Fail
ETSI EN 300 386 clause 7.2.2.4.2 / clause 7.2.2.2.2 / clause 7.2.2.3.2	Surges	<input checked="" type="checkbox"/> Pass <input type="checkbox"/> Fail
ETSI EN 300 386 clause 7.2.2.4.3 / clause 7.2.2.2.3/ clause 7.2.2.3.3	Radio frequency, conducted continuous. / Telecommunications port for indoor signal lines	<input checked="" type="checkbox"/> Pass <input type="checkbox"/> Fail
ETSI EN 300 386 clause 7.2.2.4.4	Voltage dips and short interruptions	<input checked="" type="checkbox"/> Pass <input type="checkbox"/> Fail

5.2 Performance criteria

ETSI EN 300 386 V 1.6.1 (2012-04)

For the switching equipment the following main signal ports are recognized:

- Analogue ports (e.g. analogue subscribers' lines, analogue interfaces to transmission equipment);
- Digital ports (e.g. digital subscribers' lines (ISDN), digital connections to transmission equipment).

The interfaces shall operate as described in the following clauses.

* Digital port performance criteria

Performance criterion A (continuous phenomena)

During the sweep:

- The established connections shall be maintained throughout testing and the transfer of information shall be within the limits of the manufacturer's specification;
- Loss of frame alignment or loss of synchronization is not allowed during each individual exposure (if applicable).

For selected frequencies (see clause 11.2.2):

- It shall be possible to establish a connection between two ports;
- It shall be possible to clear a connection in a controlled manner.

Performance criterion B (transient phenomena)

The established connections shall be maintained throughout testing except in the case of surge immunity testing at 1 kV where disconnection is allowed on the port being tested:

- It shall be possible to establish a connection between two ports after the end of the transient disturbances;
- It shall be possible to clear a connection in a controlled manner after the end of the transient disturbances.

Performance criterion C (interruptions)

The general performance criterion C applies.

* Analogue port performance criteria

Performance criterion A (continuous phenomena)

During the sweep:

- the established connections shall be maintained throughout testing;
- the noise level at a two wire analogue interface shall be less than -40 dBm at 600 Ω (ignoring the nominal impedance of the port for practical reasons) if not otherwise stated by the manufacturer.

The measurement shall be done selectively with a bandwidth \leq 100 Hz at 1 kHz;

- Dialing tones shall be available (if applicable).

For selected frequencies (see clause 11.2.2):

- it shall be possible to establish a connection between two ports;
- it shall be possible to clear a connection in a controlled manner.

Performance criterion B (transient phenomena)

Established connections shall be maintained throughout testing except in the case of surge immunity testing at 1 kV where disconnection is allowed on the port being tested:

- it shall be possible to establish a connection between two ports after the end of the transient disturbances;
- it shall be possible to clear a connection in a controlled manner after the end of the transient disturbances.

Performance criterion C (interruptions)

The general performance criterion C applies.

6. Test results

6.1 Conducted Emission

Test specification	ETSI EN 300 386 clause 6, Class A		
Testing voltage	230 V, 50 Hz		
Test facility	Shielded room (CE#1)		
Date	2014. 05. 12		
Temperature (°C)	22.0 °C	Humidity (% R.H.)	46.8 % R.H.
Remarks	Complied		

6.1.1 Limits of conducted emission measurement

AC main

Frequency [MHz]	Class A (dB(μ V))		Class B (dB(μ V))	
	Quasi-peak	Average	Quasi-peak	Average
0.15 ~ 0.5	79	66	66 ~ 56 *	56 ~ 46*
0.5 ~ 5	73	60	56	46
5 ~ 30	73	60	60	50

*The limit decreases linearly with the logarithm of frequency.

Telecommunication

Frequency [MHz]	Class A Voltage Limits (dB(μ V))		Current Limits (dB(μ A))	
	Quasi-Peak	Average	Quasi-Peak	Average
0.15 ~ 0.5	97 to 87	84 to 74	53 to 43	40 to 30
0.5 ~ 30	87	74	43	30
Frequency [MHz]	Class B Limits (dB(μ V))		Current Limits (dB(μ A))	
	Quasi-Peak	Average	Quasi-Peak	Average
0.15 ~ 0.5	84 to 74	74 to 64	40 to 30	30 to 20
0.5 ~ 30	74	64	30	20

* The limits decrease linearly with the logarithm of the frequency in the range 0.15 MHz to 0.5 MHz

* The current and voltage disturbance limits are derived for use with an impedance stabilization Network (ISN) which presents a common mode (asymmetric mode) impedance of 150 Ω to the telecommunication port under test (conversion factor is $20 \log_{10} 150/I = 44$ dB).

6.1.2 Measurement procedure

The measurements were performed in a shielded room. EUT was setup as shown in photograph and placed on a non-metallic table height of 0.8 m above the reference ground plane. The rear of table was located 0.4 m to the vertical conducted plane. EUT was power through the LISN, which was bonded to the ground plane. The LISN power was filtered. Each EUT power lead, except ground (safety) lead was individually connected through a LISN to input power source. EUT signal cables that hung closer than 0.4 m to the Horizontal metal ground 0.3 m ~ 0.4 m long. The power cord was bundles in the center. All peripheral equipment was powered from a sub LISN. The LISN and ISN were positioned 0.8 m from the EUT. Peak and Average detection were used in preliminary testing and Quasi-peak and Average detections were used at final measurement.

Both lines of power cord, hot and neutral, were measured.

6.1.3 Used equipments

Equipment	Model	Serial No.	Makers	Next Cal. Date	Used
Test Receiver	ESCI7	100732	R&S	2015.01.27	<input type="checkbox"/>
Test Receiver	ESCI	100001	R&S	2014.07.25	<input type="checkbox"/>
Test Receiver	ESCI	100710	R&S	2014.10.28	<input checked="" type="checkbox"/>
LISN	ENV216	101358	R&S	2014.10.04	<input checked="" type="checkbox"/>
LISN	ESH3-Z5	100267	R&S	2014.07.08	<input checked="" type="checkbox"/>
8-WIRE ISN	NTFM 8158 CAT5	CAT5-8158-0071	SCHWARZBECK	2015.02.25	<input checked="" type="checkbox"/>
8-WIRE ISN	NTFM 8158 CAT3	CAT3-8158-0020	SCHWARZBECK	2015.03.07	<input type="checkbox"/>
ISN	ST08	24342	TESEQ	2014.06.21	<input type="checkbox"/>

6.1.4 Photographs of test setup

* AC main

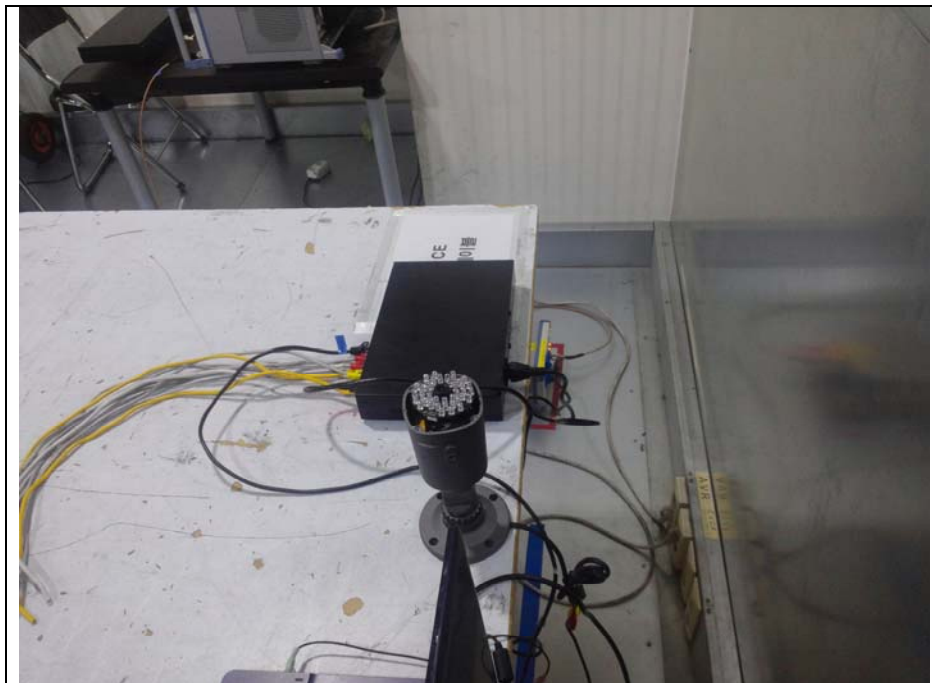
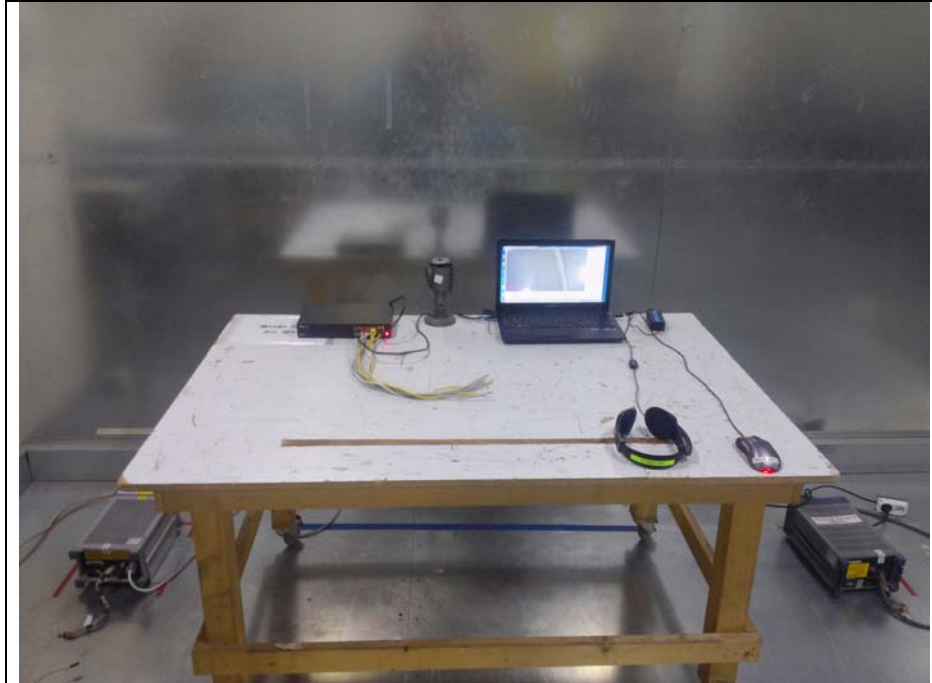

* Telecommunication

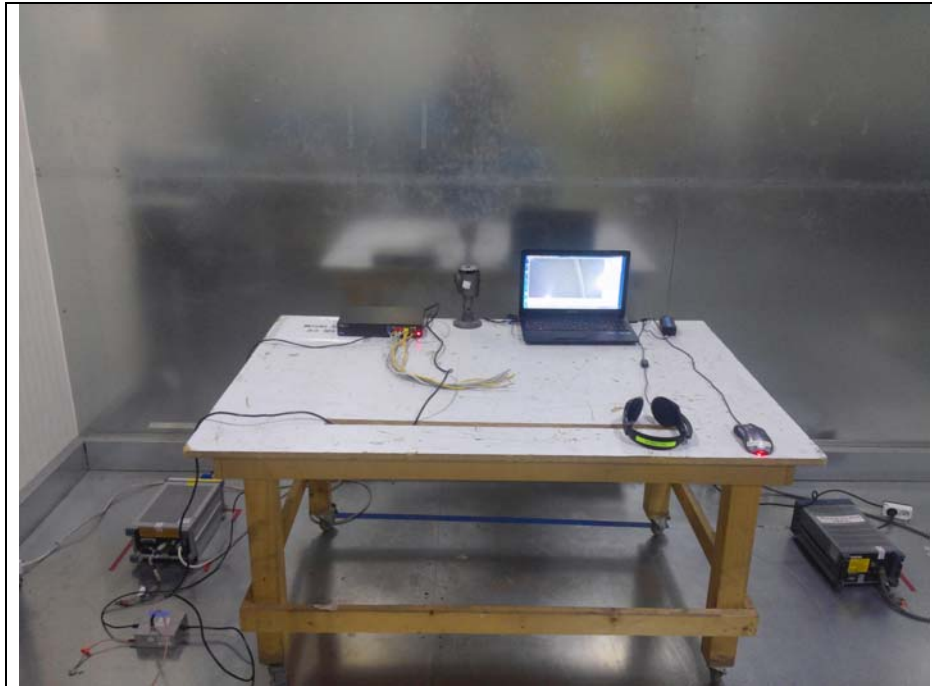

6.1.5 Conducted emission measurement result

* AC Main (DH-2010P)

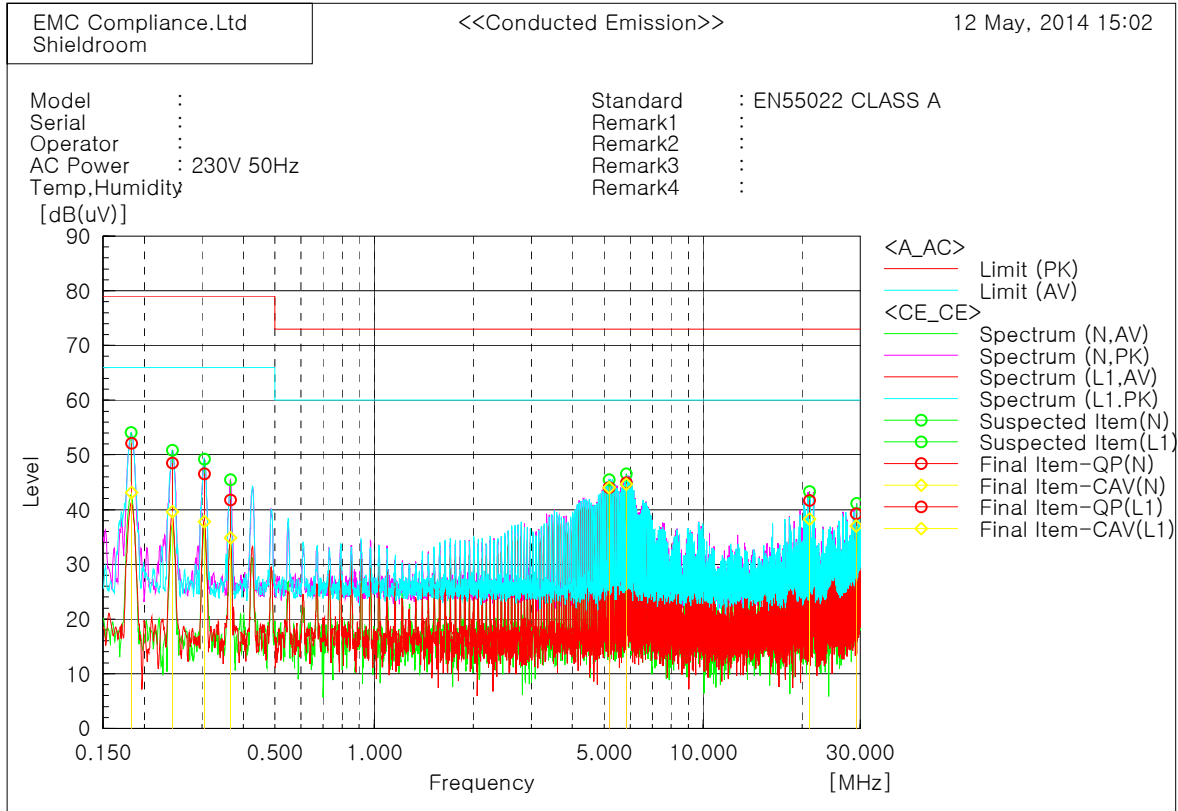

Final Result

--- N Phase ---

No.	Frequency [MHz]	Reading QP [dB(uV)]	Reading CAV [dB(uV)]	c. f [dB]	Result QP [dB(uV)]	Result CAV [dB(uV)]	Limit QP [dB(uV)]	Limit AV [dB(uV)]	Margin QP [dB]	Margin CAV [dB]
1	0.3055	36.7	27.9	9.9	46.6	37.8	79.0	66.0	32.4	28.2
2	0.3662	31.8	24.8	10.0	41.8	34.8	79.0	66.0	37.2	31.2
3	5.17247	34.3	34.3	9.7	44.0	44.0	73.0	60.0	29.0	16.0
4	21.05188	31.8	28.3	9.9	41.7	38.2	73.0	60.0	31.3	21.8

--- L1 Phase ---

No.	Frequency [MHz]	Reading QP [dB(uV)]	Reading CAV [dB(uV)]	c. f [dB]	Result QP [dB(uV)]	Result CAV [dB(uV)]	Limit QP [dB(uV)]	Limit AV [dB(uV)]	Margin QP [dB]	Margin CAV [dB]
1	0.18305	42.0	33.0	10.1	52.1	43.1	79.0	66.0	26.9	22.9
2	0.24343	38.7	29.8	9.8	48.5	39.6	79.0	66.0	30.5	26.4
3	5.84272	35.3	35.1	9.6	44.9	44.7	73.0	60.0	28.1	15.3
4	29.23476	29.5	27.2	9.8	39.3	37.0	73.0	60.0	33.7	23.0

* Telecommunication port

LCL 65 dB (Cascade(RJ-45) Port (LCL 65 dB)_10 Mbps) (DH-2010P)_UP Link

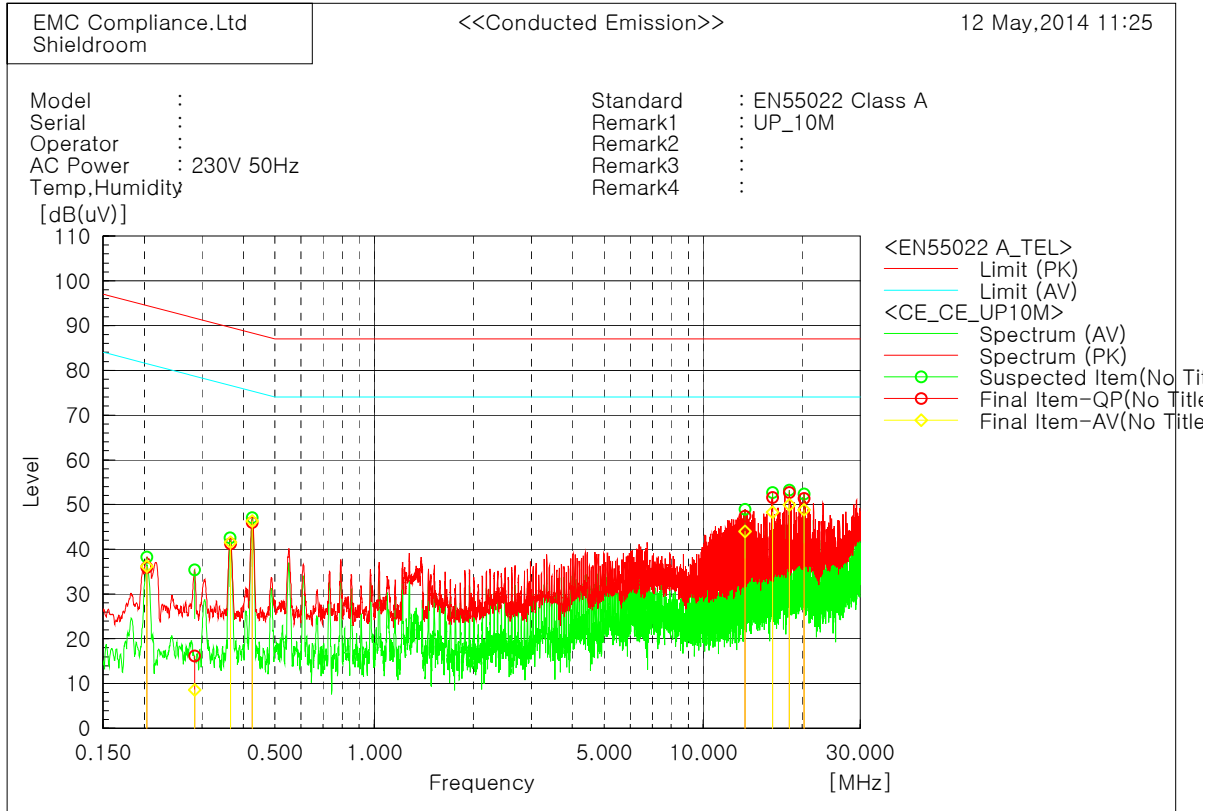

Final Result

--- ISN-CAT5 Phase ---

No.	Frequency [MHz]	Reading QP [dB(uV)]	Reading CAV [dB(uV)]	c.f [dB]	Result QP [dB(uV)]	Result CAV [dB(uV)]	Limit QP [dB(uV)]	Limit AV [dB(uV)]	Margin QP [dB]	Margin CAV [dB]
1	0.20353	26.3	26.5	9.7	36.0	36.2	94.5	81.5	58.5	45.3
2	0.28446	6.5	-1.0	9.6	16.1	8.6	91.7	78.7	75.6	70.1
3	0.36552	31.7	32.1	9.5	41.2	41.6	89.6	76.6	48.4	35.0
4	0.42648	36.5	36.8	9.5	46.0	46.3	88.3	75.3	42.3	29.0
5	13.41971	38.1	34.6	9.4	47.5	44.0	87.0	74.0	39.5	30.0
6	16.22825	42.1	38.9	9.4	51.5	48.3	87.0	74.0	35.5	25.7
7	18.24285	43.2	40.4	9.5	52.7	49.9	87.0	74.0	34.3	24.1
8	20.25792	41.9	39.4	9.5	51.4	48.9	87.0	74.0	35.6	25.1

LCL 65 dB (Cascade(RJ-45) Port (LCL 65 dB)_1000 Mbps) (DH-2010P)_UP Link

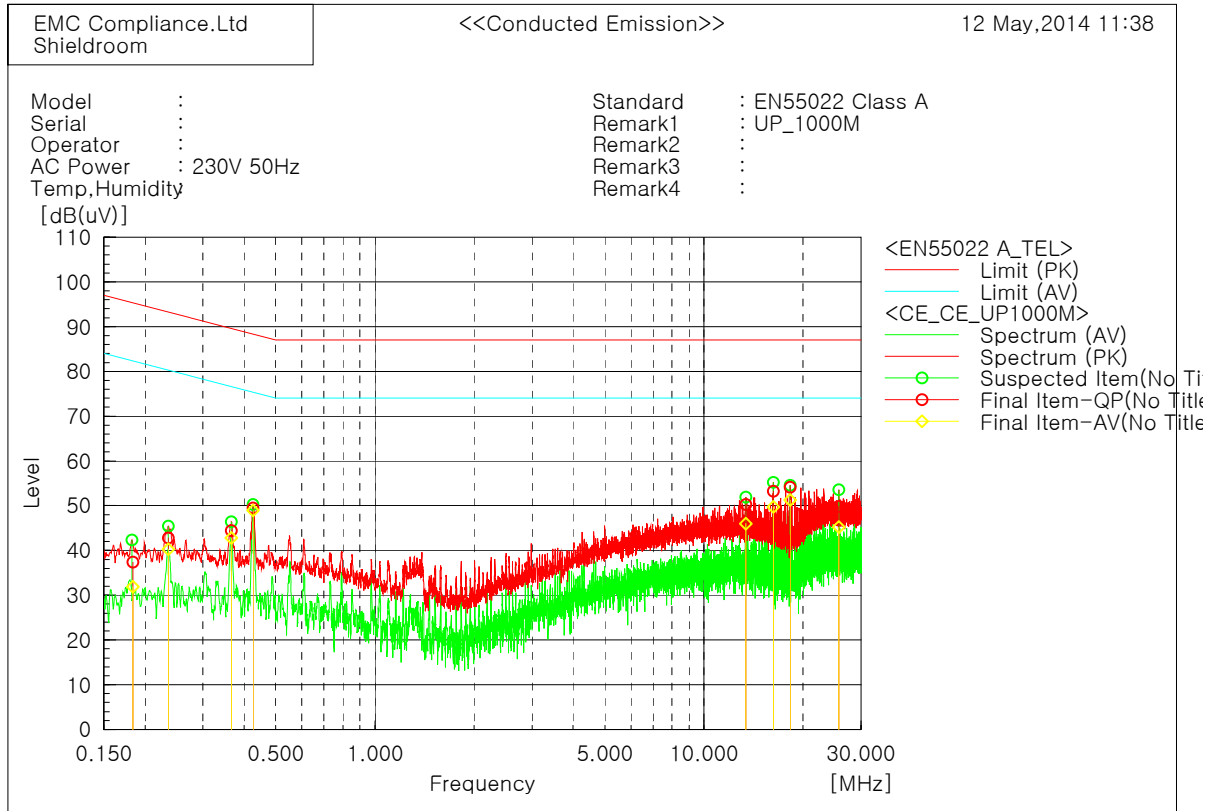

Final Result

--- ISN-CAT5 Phase ---

No.	Frequency [MHz]	Reading QP [dB(uV)]	Reading CAV [dB(uV)]	c. f [dB]	Result QP [dB(uV)]	Result CAV [dB(uV)]	Limit QP [dB(uV)]	Limit AV [dB(uV)]	Margin QP [dB]	Margin CAV [dB]
1	0.18399	27.7	22.2	9.7	37.4	31.9	95.3	82.3	57.9	50.4
2	0.23578	33.1	30.6	9.7	42.8	40.3	93.2	80.2	50.4	39.9
3	0.36588	34.9	33.3	9.5	44.4	42.8	89.6	76.6	45.2	33.8
4	0.42611	39.9	39.5	9.5	49.4	49.0	88.3	75.3	38.9	26.3
5	13.41893	40.8	36.6	9.4	50.2	46.0	87.0	74.0	36.8	28.0
6	16.22794	43.8	40.3	9.4	53.2	49.7	87.0	74.0	33.8	24.3
7	18.24306	44.7	41.7	9.5	54.2	51.2	87.0	74.0	32.8	22.8
8	25.69242	40.2	35.6	9.6	49.8	45.2	87.0	74.0	37.2	28.8

LCL 65 dB (PoE(RJ-45) Port (LCL 65 dB)_10 Mbps) (DH-2010P)_Down Link

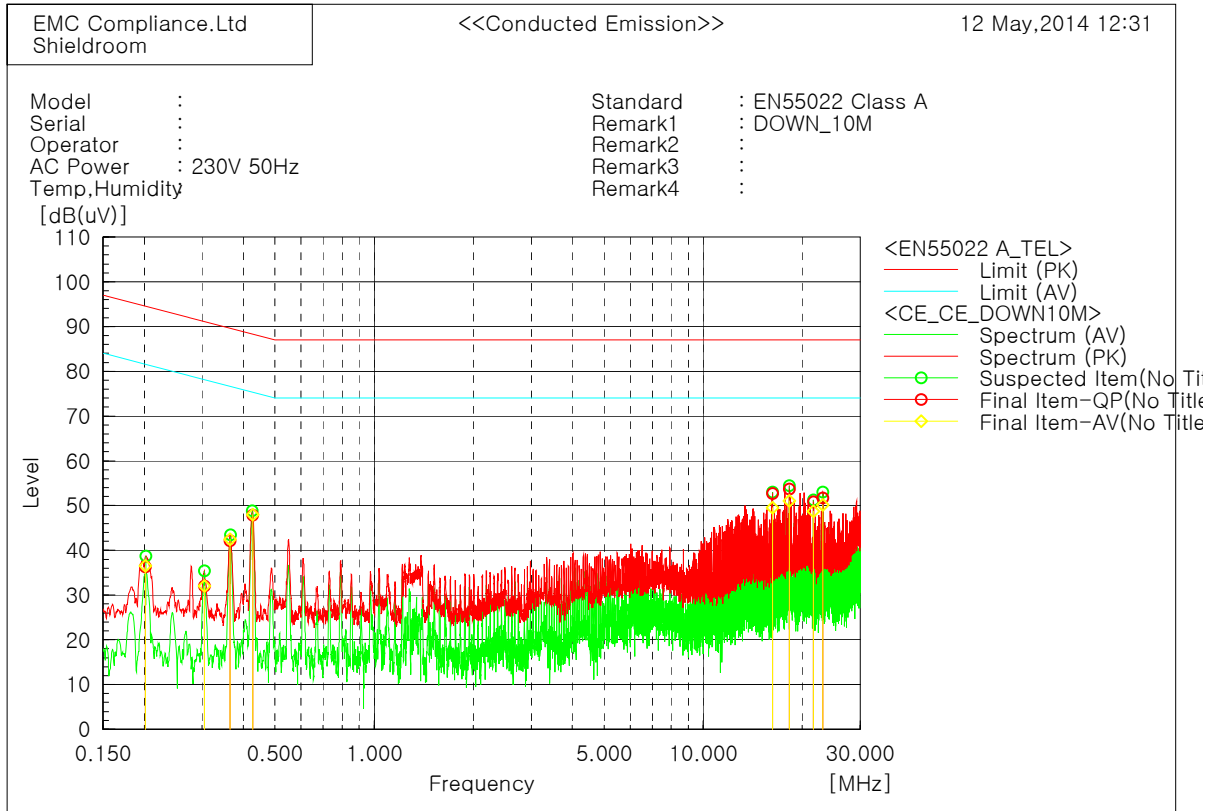

Final Result

--- ISN-CAT5 Phase ---

No.	Frequency [MHz]	Reading QP [dB(uV)]	Reading CAV [dB(uV)]	c. f [dB]	Result QP [dB(uV)]	Result CAV [dB(uV)]	Limit QP [dB(uV)]	Limit AV [dB(uV)]	Margin QP [dB]	Margin CAV [dB]
1	0.20165	26.7	26.8	9.7	36.4	36.5	94.5	81.5	58.1	45.0
2	0.30544	22.4	22.4	9.6	32.0	32.0	91.1	78.1	59.1	46.1
3	0.36495	32.6	33.0	9.5	42.1	42.5	89.6	76.6	47.5	34.1
4	0.42705	38.3	38.5	9.5	47.8	48.0	88.3	75.3	40.5	27.3
5	16.22784	43.3	40.1	9.4	52.7	49.5	87.0	74.0	34.3	24.5
6	18.24285	44.2	41.5	9.5	53.7	51.0	87.0	74.0	33.3	23.0
7	21.6625	41.3	39.3	9.5	50.8	48.8	87.0	74.0	36.2	25.2
8	23.12717	42.2	40.6	9.6	51.8	50.2	87.0	74.0	35.2	23.8

LCL 65 dB (PoE(RJ-45) Port (LCL 65 dB)_100 Mbps) (DH-2010P)_Down Link

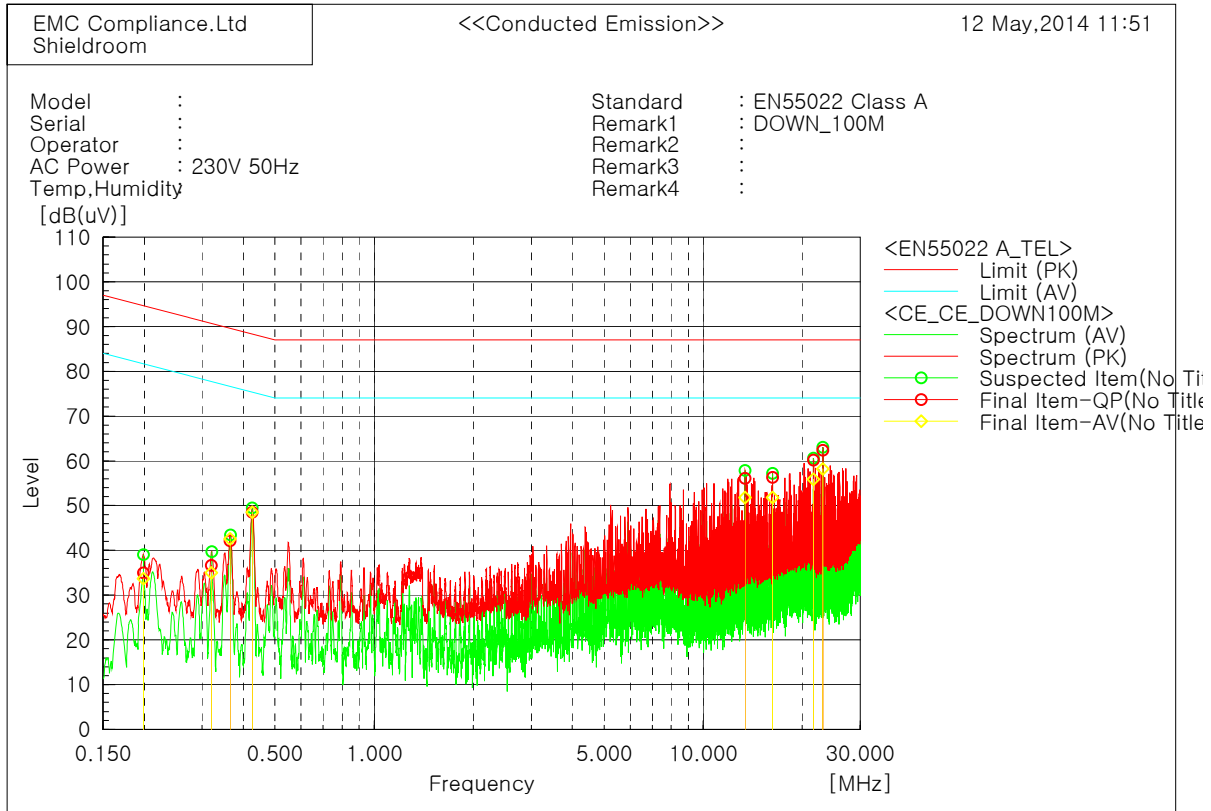

Final Result

--- ISN-CAT5 Phase ---

No.	Frequency [MHz]	Reading QP [dB(μV)]	Reading CAV [dB(μV)]	c. f [dB]	Result QP [dB(μV)]	Result CAV [dB(μV)]	Limit QP [dB(μV)]	Limit AV [dB(μV)]	Margin QP [dB]	Margin CAV [dB]
1	0.19896	25.3	23.9	9.7	35.0	33.6	94.7	81.7	59.7	48.1
2	0.3204	27.1	25.4	9.6	36.7	35.0	90.7	77.7	54.0	42.7
3	0.36501	32.7	33.0	9.5	42.2	42.5	89.6	76.6	47.4	34.1
4	0.4264	39.0	39.0	9.5	48.5	48.5	88.3	75.3	39.8	26.8
5	13.41911	46.7	42.4	9.4	56.1	51.8	87.0	74.0	30.9	22.2
6	16.22848	46.9	42.4	9.4	56.3	51.8	87.0	74.0	30.7	22.2
7	21.66375	50.6	46.4	9.5	60.1	55.9	87.0	74.0	26.9	18.1
8	23.12874	52.7	48.6	9.6	62.3	58.2	87.0	74.0	24.7	15.8

6.2 Radiated Emission

Test specification	ETSI EN 300 386 clause 6, Class A		
Testing voltage	230 V, 50 Hz		
Test facility	10 m Chamber (#F2)		
Test distance	10 m, 3 m		
Date	2014. 05. 08		
Temperature (°C)	20.6 °C	Humidity (% R.H.)	36.9 % R.H.
Remarks	Complied		

6.2.1 Limits of radiated emission measurement

Limits below 1 GHz

Frequency [MHz]	Class A (dB(μV/m)) @ 10 m	Class B (dB(μV/m)) @ 10 m
30 ~ 230	40	30
230 ~ 1 000	47	37

Limits above 1 GHz

Frequency [MHz]	Class A (dB(μV))		Class B (dB(μV))	
	Average limit (dB(μV/m))	Peak limit (dB(μV/m))	Average limit (dB(μV/m))	Peak limit (dB(μV/m))
1 ~ 3	56	76	50	70
3 ~ 6	60	80	54	74

Note - The lower limit applies at the transition frequency.

6.2.2 Measurement procedure

The test was done at a 10 m chamber with a quasi-peak detector. EUT was placed on a non-metallic table height of 0.8 m above the reference ground plane. Cables were folded back and forth forming a bundle 0.3 m to 0.4 m long and were hanged at a 0.4 m height to the ground plane. Cables connected to EUT were fixed to cause maximum emission. Test was made with the antenna positioned in both the horizontal and vertical planes of polarization. The measurement antenna was varied in height above the conducting ground plane to obtain the maximum signal strength.

6.2.3 Used equipments

Equipment	Model no.	Serial no.	Makers	Next Cal. Date	Used
Test Receiver	ESCI7	100732	R&S	2015.01.27	<input type="checkbox"/>
Test Receiver	ESCI	100001	R&S	2014.07.25	<input type="checkbox"/>
Test Receiver	ESCI	100710	R&S	2014.10.28	<input type="checkbox"/>
Test Receiver	ESR	101078	R&S	2015.02.24	<input checked="" type="checkbox"/>
Bi-Log Antenna	VULB 9168	440	SCHWARZBECK	2015.10.16	<input checked="" type="checkbox"/>
Amplifier	310N	293004	SONOMA INSTRUMENT	2014.10.31	<input checked="" type="checkbox"/>
3 dB Attenuator	8491B	22981	HP	2015.03.04	<input checked="" type="checkbox"/>
Antenna Mast	MA4000-EP	303	Innco Systems	-	<input checked="" type="checkbox"/>
Turn Table	DT2000S-1t	079	Innco Systems	-	<input checked="" type="checkbox"/>
Amplifier	8449B	3008A02343	AGILENT	2014.10.31	<input checked="" type="checkbox"/>
Horn ANT	3115	00155772	ETS	2015.02.26	<input checked="" type="checkbox"/>
Spectrum Analyzer	FSP7	100289	R&S	2014.11.25	<input type="checkbox"/>

6.2.4 Sample calculation

The field strength is calculated adding the antenna Factor, cable loss and, Antenna pad adding, subtracting the amplifier gain from the measured reading.

The sample calculation is as follow:

$$\text{Result} = \text{M.R} + \text{C.F}(\text{A.F} + \text{C.L} + 3 \text{ dB Att} - \text{A.G})$$

M.R = Meter Reading

C.F = Correction Factor

A.F = Antenna Factor

C.L = Cable Loss

A.G= Amplifier Gain

3 dB Att = 3 dB Attenuator

If M.R is 30 dB, A.F 12 dB, C.L 5 dB, 3 dB, A.G 35 dB

The result is

$$30 + 12 + 5 + 3 - 35 = 15 \text{ dB}(\mu\text{V/m})$$

6.2.5 Photographs of test setup

* 30 MHz ~ 1 GHz

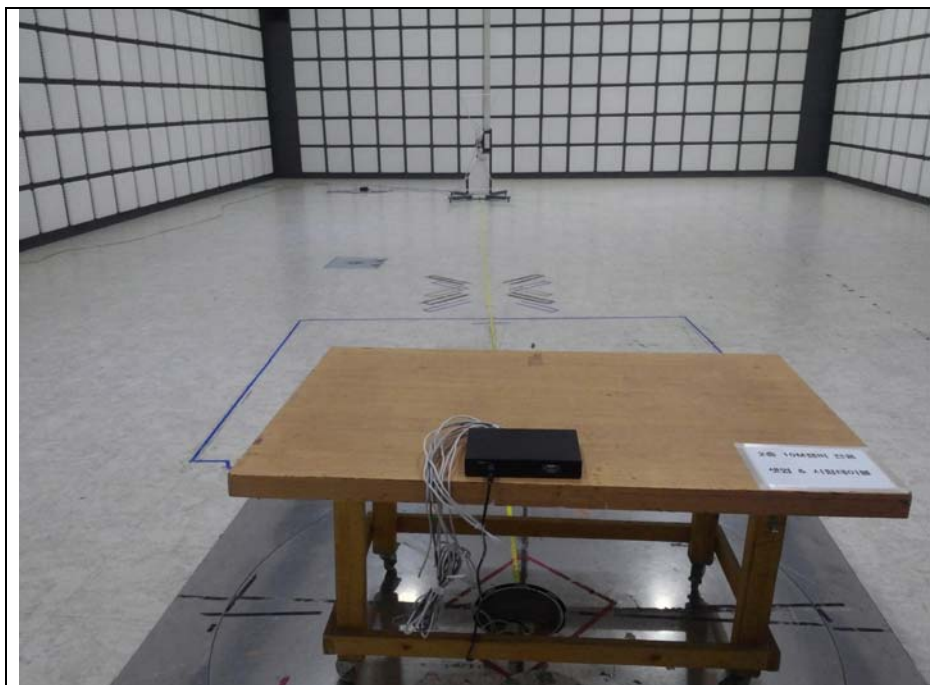
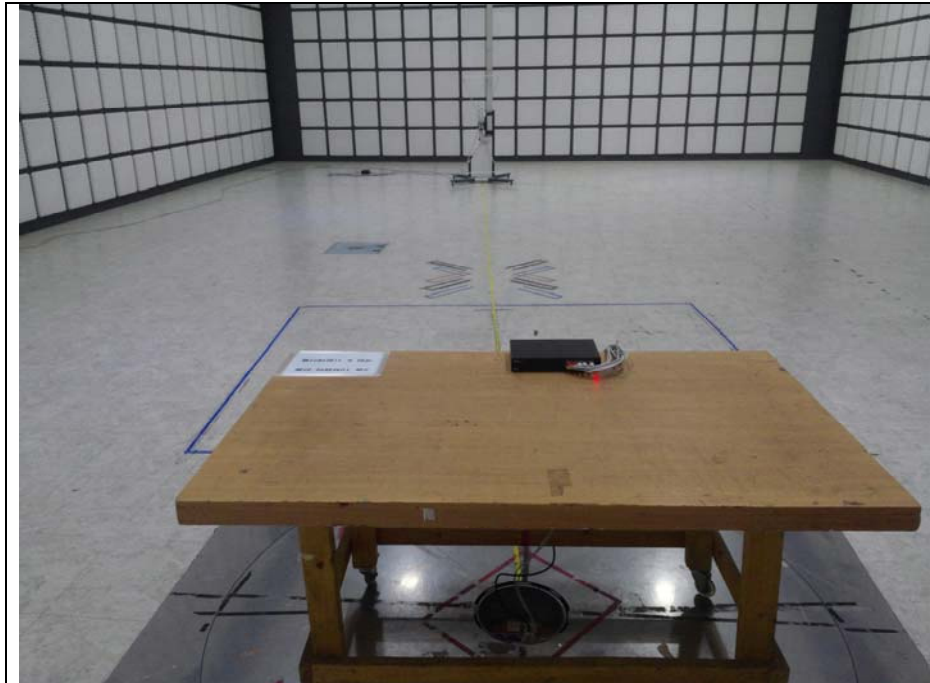

* 1 GHz ~ 6 GHz

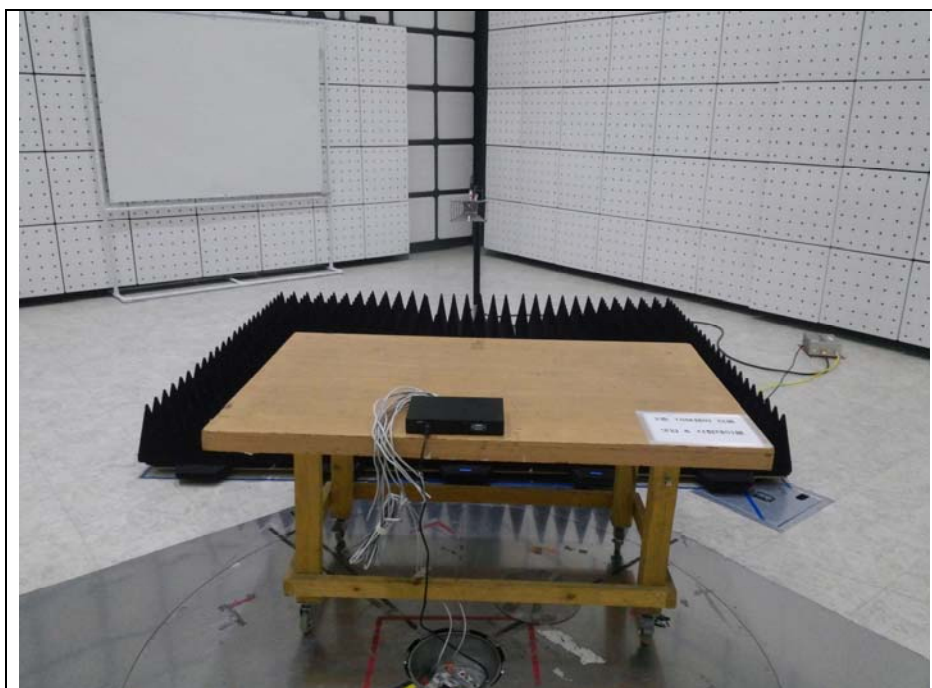
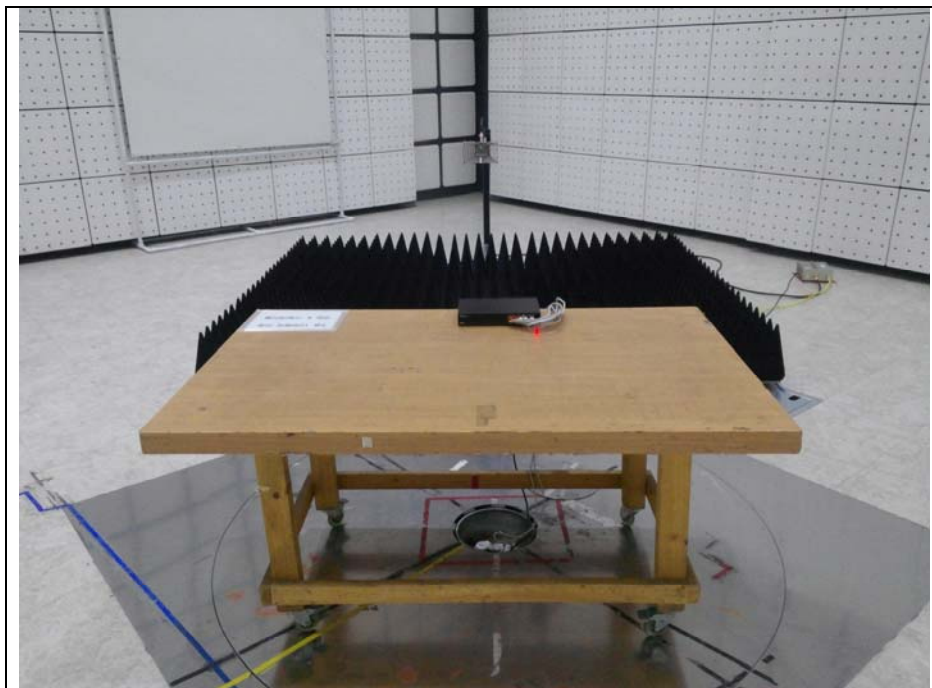

6.2.6 Radiated emission measurement result

* Graph and Data

* 30 MHz ~ 1 GHz (DH-2010P)

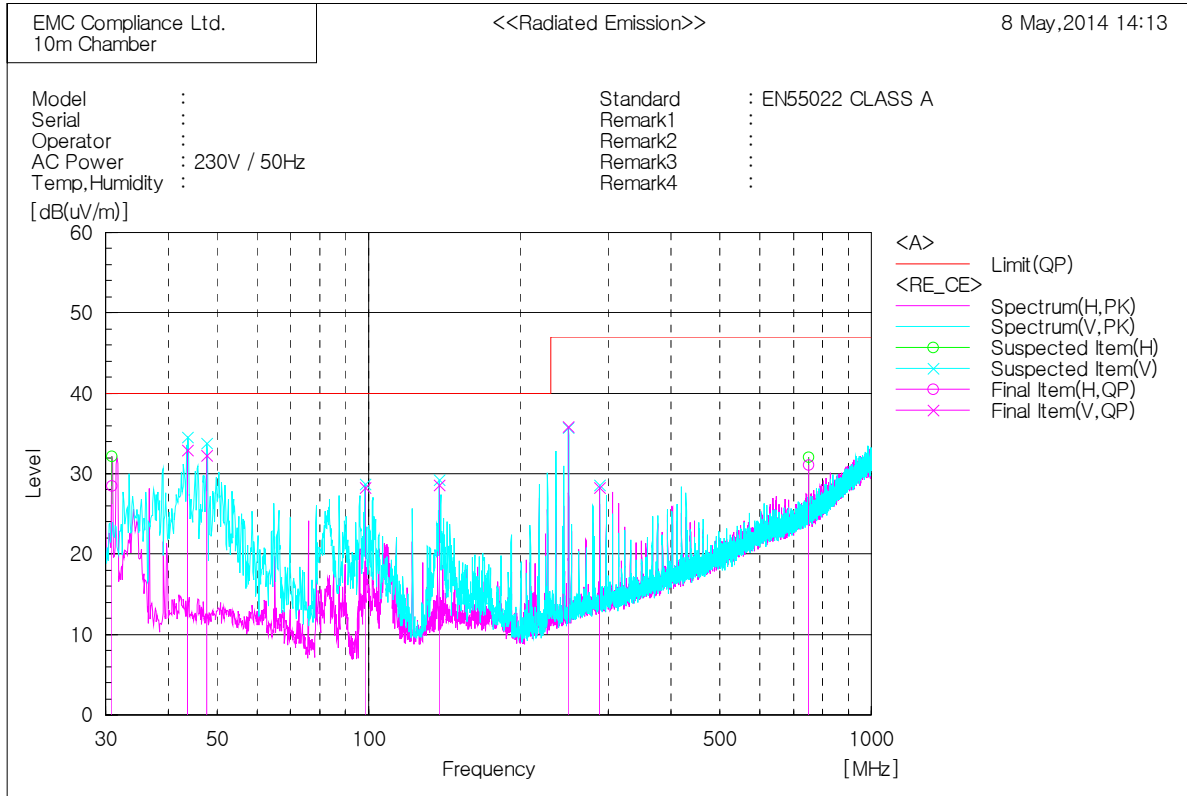

Final Result

No.	Frequency [MHz]	(P)	Reading QP [dB(uV)]	c. f [dB(1/m)]	Result QP [dB(uV/m)]	Limit QP [dB(uV/m)]	Margin QP [dB]	Height [cm]	Angle [deg]
1	30.849	H	43.6	-15.1	28.5	40.0	11.5	400.0	49.0
2	43.701	V	46.3	-13.4	32.9	40.0	7.1	100.0	21.6
3	47.703	V	45.6	-13.3	32.3	40.0	7.7	100.0	21.6
4	98.385	V	46.0	-17.7	28.3	40.0	11.7	100.0	6.6
5	138.398	V	42.3	-13.7	28.6	40.0	11.4	100.0	6.6
6	249.947	V	48.2	-12.3	35.9	47.0	11.1	100.0	75.9
7	288.384	V	39.1	-10.8	28.3	47.0	18.7	100.0	6.6
8	750.104	H	30.6	0.5	31.1	47.0	15.9	100.0	197.1

* 1 GHz ~ 6 GHz (DH-2010P)

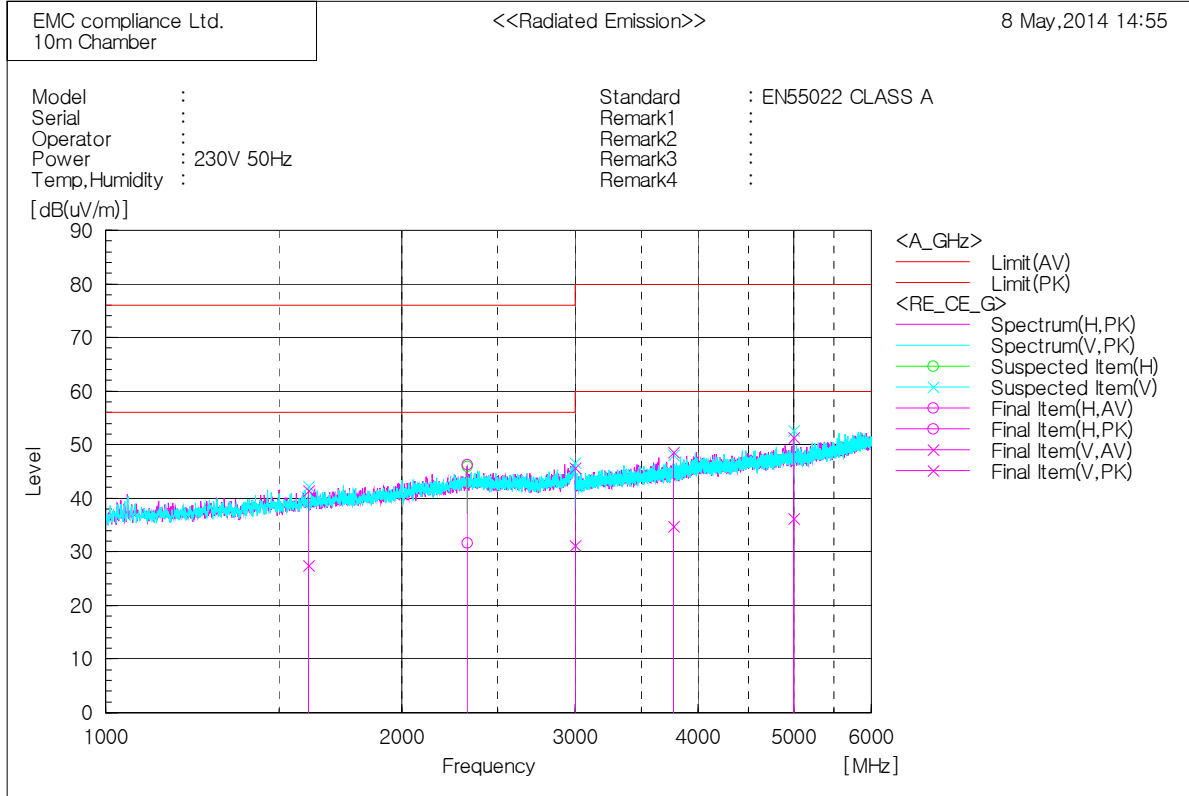

Final Result

No.	Frequency [MHz]	(P)	Reading AV [dB(uV)]	Reading PK [dB(uV)]	c.f [dB(1/m)]	Result AV [dB(uV/m)]	Result PK [dB(uV/m)]	Limit AV [dB(uV/m)]	Limit PK [dB(uV/m)]	Margin AV [dB]	Margin PK [dB]	Height [cm]	Angle [deg]
1	1606.875	V	30.6	44.6	-3.1	27.5	41.5	56.0	76.0	28.5	34.5	100.0	311.4
2	2328.125	H	30.6	45.2	1.1	31.7	46.3	56.0	76.0	24.3	29.7	100.0	131.4
3	3000.000	V	29.8	44.3	1.4	31.2	45.7	56.0	76.0	24.8	30.3	100.0	110.8
4	3780.625	V	30.3	44.1	4.5	34.8	48.6	60.0	80.0	25.2	31.4	100.0	282.7
5	5000.625	V	28.4	43.5	7.9	36.3	51.4	60.0	80.0	23.7	28.6	100.0	317.4

6.3 Harmonics

Test specification	EN 61000-3-2:2006+A1:2009+A2:2009				
Testing voltage	230 V, 50 Hz				
Test facility	Immunity area				
Date	2014. 05. 07				
Temperature(°C)	24.6 °C	Humidity (% R.H.)	40.2 % R.H.	Pressure (kPa)	100.4 kPa
Remarks	Complied				

6.3.1 Measurement procedure

The equipment is supplied in series with shunt(s) Rm or current transformer(s) from a source having the same nominal voltage and frequency as the rated supply voltage and frequency of the equipment. Measurements shall be made under normal load, or conditions for adequate heat discharge, and under normal operating conditions. User's operation controls or automatic programmers shall be set to produce the maximum harmonic component, for each successive harmonic component in turn. For the purpose of harmonic current limitation, equipment is classified as follows :

Class A : Equipment not specified in one of the three other Classes shall be considered as Class A equipment.

- Balanced three-phase equipment;
- Household appliances excluding equipment identified as Class D;
- Tools excluding portable tools;
- Dimmers for incandescent lamps;
- Audio equipment.

Class B : Portable tools; Arc welding equipment which is not professional equipment.

Class C : Lighting equipment.

Class D : Equipment having a specified power according to 6.2.2 less than or equal to

600 w, of the following types:

- Personal computers and personal computer monitors;
- Television receivers.

6.3.2 Used equipments

Equipment	Model no.	Serial no.	Makers	Next Cal. date	Used
Harmonics/Flicker meter	5001x-CTS -400-413	54984	C.I.	2015.04.17	<input checked="" type="checkbox"/>

6.3.3 Photographs of test setup



6.3.4 Measurement result

Harmonics – Class-A per Ed. 3.2 (2009)(Run time) incl. inter-harmonics

EUT: DH-2010P
 Test category: Class-A per Ed. 3.2 (2009) (European limits)
 Test date: 2014-05-07
 Test duration (min): 2.5
 Comment: POE SWITCH
 Customer: IDIS

Tested by: Tested by
 Test Margin: 100
 Start time: 오후 7:12:18
 End time: 오후 7:15:08
 Data file name: H-000167.cts_data

Test Result: Pass Source qualification: Normal

Current & voltage waveforms

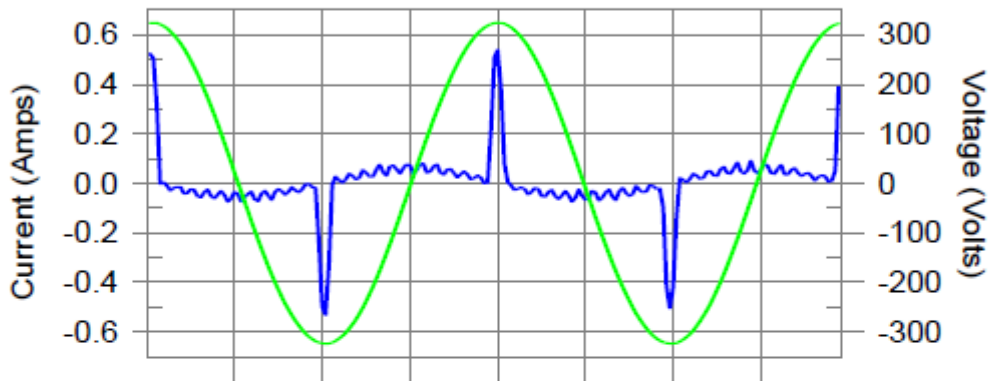

Harmonics and Class A limit line European Limits

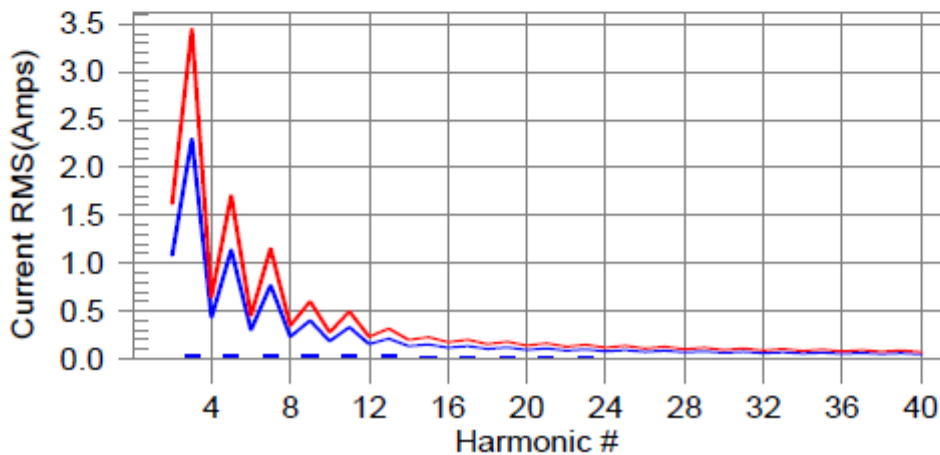

Test result: Pass Worst harmonic was #15 with 18.59% of the limit.

Current Test Result Summary (Run time)

EUT: DH-2010P
Test category: Class-A per Ed. 3.2 (2009) (European limits)
Test date: 2014-05-07
Test duration (min): 2.5
Comment: POE SWITCH
Customer: IDIS

Tested by: Tested by
Test Margin: 100
Start time: 오후 7:12:18
End time: 오후 7:15:08
Data file name: H-000167.cts_data

Test Result: Pass Source qualification: Normal
THC(A): 0.11 I-THD(%): 179.57 POHC(A): 0.022 POHC Limit(A): 0.251
Highest parameter values during test:
V_RMS (Volts): 229.55 Frequency(Hz): 50.00
I_Peak (Amps): 0.601 I_RMS (Amps): 0.126
I_Fund (Amps): 0.071 Crest Factor: 4.831
Power (Watts): 10.5 Power Factor: 0.370

Harm#	Harms(avg)	100%Limit	%of Limit	Harms(max)	150%Limit	%of Limit	Status
2	0.002	1.080	0.0	0.002	1.620	0.11	Pass
3	0.045	2.300	2.0	0.046	3.450	1.32	Pass
4	0.002	0.430	0.0	0.002	0.645	0.30	Pass
5	0.044	1.140	3.8	0.044	1.710	2.56	Pass
6	0.002	0.300	0.0	0.002	0.450	0.38	Pass
7	0.042	0.770	5.4	0.042	1.155	3.60	Pass
8	0.002	0.230	0.0	0.002	0.345	0.49	Pass
9	0.039	0.400	9.7	0.039	0.600	6.48	Pass
10	0.001	0.184	0.0	0.002	0.276	0.57	Pass
11	0.035	0.330	10.8	0.036	0.495	7.19	Pass
12	0.001	0.153	0.0	0.002	0.230	0.71	Pass
13	0.032	0.210	15.2	0.032	0.315	10.14	Pass
14	0.001	0.131	0.0	0.001	0.197	0.71	Pass
15	0.028	0.150	18.6	0.028	0.225	12.43	Pass
16	0.001	0.115	0.0	0.001	0.173	0.74	Pass
17	0.024	0.132	18.0	0.024	0.199	12.00	Pass
18	0.001	0.102	0.0	0.001	0.153	0.80	Pass
19	0.020	0.118	16.6	0.020	0.178	11.12	Pass
20	0.001	0.092	0.0	0.001	0.138	0.77	Pass
21	0.016	0.107	14.6	0.016	0.161	9.80	Pass
22	0.001	0.084	0.0	0.001	0.125	0.79	Pass
23	0.012	0.098	12.1	0.012	0.147	8.13	Pass
24	0.001	0.077	0.0	0.001	0.115	0.77	Pass
25	0.008	0.090	9.3	0.008	0.135	6.28	Pass
26	0.001	0.071	0.0	0.001	0.106	0.82	Pass
27	0.005	0.083	6.3	0.005	0.125	4.30	Pass
28	0.001	0.066	0.0	0.001	0.099	0.71	Pass
29	0.003	0.078	0.0	0.003	0.116	2.34	Pass
30	0.001	0.061	0.0	0.001	0.092	0.76	Pass
31	0.001	0.073	0.0	0.001	0.109	0.78	Pass
32	0.001	0.058	0.0	0.001	0.086	0.79	Pass
33	0.002	0.068	0.0	0.002	0.102	1.77	Pass
34	0.001	0.054	0.0	0.001	0.081	0.85	Pass
35	0.003	0.064	0.0	0.003	0.096	3.14	Pass
36	0.001	0.051	0.0	0.001	0.077	0.90	Pass
37	0.004	0.061	0.0	0.004	0.091	4.17	Pass
38	0.001	0.048	0.0	0.001	0.073	0.98	Pass
39	0.004	0.058	0.0	0.004	0.087	4.87	Pass
40	0.001	0.046	0.0	0.001	0.069	0.94	Pass

Voltage Source Verification Data (Run time)

EUT: DH-2010P
Test category: Class-A per Ed. 3.2 (2009) (European limits)
Test date: 2014-05-07
Test duration (min): 2.5
Comment: POE SWITCH
Customer: IDIS

Tested by: Tested by
Test Margin: 100
Start time: 오후 7:12:18
End time: 오후 7:15:08
Data file name: H-000167.cts_data

Test Result: Pass Source qualification: Normal

Highest parameter values during test:

Voltage (Vrms): 229.55
I_{Peak} (Amps): 0.601
I_{Fund} (Amps): 0.071
Power (Watts): 10.5

Frequency(Hz): 50.00
I_{RMS} (Amps): 0.126
Crest Factor: 4.831
Power Factor: 0.370

Harm#	Harmonics V-rms	Limit V-rms	% of Limit	Status
2	0.099	0.459	21.58	OK
3	0.542	2.066	26.22	OK
4	0.021	0.459	4.61	OK
5	0.014	0.918	1.53	OK
6	0.022	0.459	4.70	OK
7	0.015	0.689	2.18	OK
8	0.017	0.459	3.62	OK
9	0.032	0.459	6.99	OK
10	0.008	0.459	1.83	OK
11	0.019	0.230	8.28	OK
12	0.022	0.230	9.46	OK
13	0.044	0.230	19.16	OK
14	0.007	0.230	3.18	OK
15	0.020	0.230	8.91	OK
16	0.011	0.230	4.90	OK
17	0.028	0.230	12.03	OK
18	0.017	0.230	7.28	OK
19	0.028	0.230	12.34	OK
20	0.003	0.230	1.42	OK
21	0.024	0.230	10.63	OK
22	0.009	0.230	3.80	OK
23	0.017	0.230	7.33	OK
24	0.007	0.230	3.20	OK
25	0.021	0.230	8.96	OK
26	0.009	0.230	3.82	OK
27	0.014	0.230	6.21	OK
28	0.007	0.230	3.03	OK
29	0.017	0.230	7.50	OK
30	0.010	0.230	4.57	OK
31	0.010	0.230	4.45	OK
32	0.007	0.230	2.88	OK
33	0.012	0.230	5.04	OK
34	0.007	0.230	3.00	OK
35	0.007	0.230	2.96	OK
36	0.005	0.230	1.97	OK
37	0.008	0.230	3.46	OK
38	0.006	0.230	2.64	OK
39	0.012	0.230	5.22	OK
40	0.009	0.230	3.79	OK

6.4 Flicker

Test specification	EN 61000-3-3:2008				
Testing voltage	230 V, 50 Hz				
Test facility	Immunity area				
Date	2014. 05. 07				
Temperature(°C)	24.6 °C	Humidity (% R.H.)	40.2 % R.H.	Pressure (kPa)	100.4 kPa
Remarks	Complied				

6.4.1 Measurement procedure

EUT was connected to the power analyzer system.

Measurement was performed to obtain the desired flicker parameters.

The measuring time depends on which parameters are to be measured.

$$P_{It} = 2 \text{ h}$$

$$P_{st} = 10 \text{ min}$$

Controls and automatic programs shall be set to produce the most unfavorable sequence of voltage changes, using only those combinations of controls and programs are mentioned by the manufacturer in the instruction manual.

6.4.2 Used equipments

Equipment	Model no.	Serial no.	Makers	Next Cal. date	Used
Harmonics/Flicker meter	5001x-CTS -400-413	54984	C.I.	2015.04.17	<input checked="" type="checkbox"/>

6.4.3 Photographs of test setup



6.4.4 Measurement result

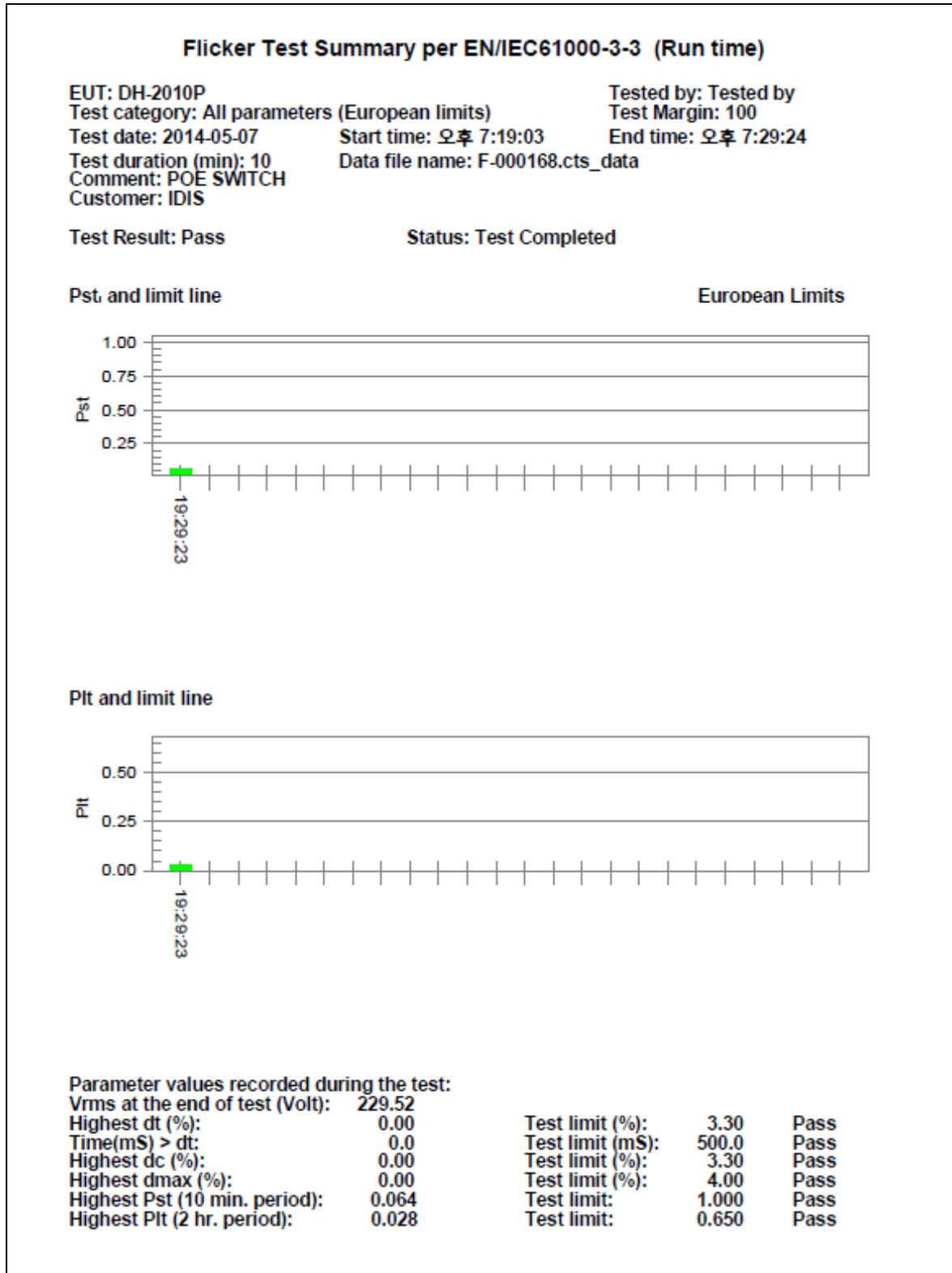

6.5 Electrostatic Discharge

Test specification	ETSI EN 300 386 clause 7.2.2.1.1, Criteria : B				
Test level	<input checked="" type="checkbox"/> Contact: ± 6 kV <input checked="" type="checkbox"/> Air: ± 2 kV, ± 4 kV, ± 8 kV <input checked="" type="checkbox"/> HCP: ± 2 kV, ± 4 kV, ± 6 kV <input checked="" type="checkbox"/> VCP: ± 2 kV, ± 4 kV, ± 6 kV				
Discharge impedance	330 Ω / 150 pF				
Number of discharge (Each polarity)	<input checked="" type="checkbox"/> Contact: 10 <input checked="" type="checkbox"/> Air: 10 <input checked="" type="checkbox"/> HCP / VCP: 10				
Interval between discharges	1 s				
Testing voltage	230 V, 50 Hz				
Test facility	Shielded room				
Date	2014. 05. 07				
Temperature($^{\circ}$ C)	24.6 $^{\circ}$ C	Humidity (% R.H.)	40.2 % R.H.	Pressure (kPa)	100.4 kPa
Remarks	Complied - A: There was no change of operation status during above testing.				

6.5.1 Measurement procedure

A ground reference plane was located on the floor, and connected to earth via a low Impedance connection. The return cable of the ESD generator was connected to the reference plane. In case of floor standing equipment, EUT was placed on the reference plane on 0.1 m of insulating Support. In case of table top equipment, EUT was placed on a wooden table 0.8 m above the reference grounded floor. A horizontal coupling plane(HCP) was placed on the table, and Connected to the reference plane via a 470 k Ω resistor located in each end (0.5 mm insulating support between EUT and HCP). In both cases a vertical coupling plane(VCP) OF 0.5 X 0.5 m was located 0.1 m from the EUT's sides. The VCP was connected to the reference plane in the same matter as the HCP.

6.5.2 Used equipments

Equipment	Model No.	Serial No.	Makers	Next Cal. Date	Used
ESD Tester	PESD 1600	H011 309	HAEFELY	2014.07.15	<input type="checkbox"/>
ESD Tester	NSG 437	182	TESEQ	2015.04.09	<input checked="" type="checkbox"/>
HCP	-	-	-	-	<input checked="" type="checkbox"/>
VCP	-	-	-	-	<input checked="" type="checkbox"/>

6.5.3 Photographs of test setup



6.5.4 Measurement result

Electrostatic Discharge (Test Point)

Air discharge	→
Contact discharge	→

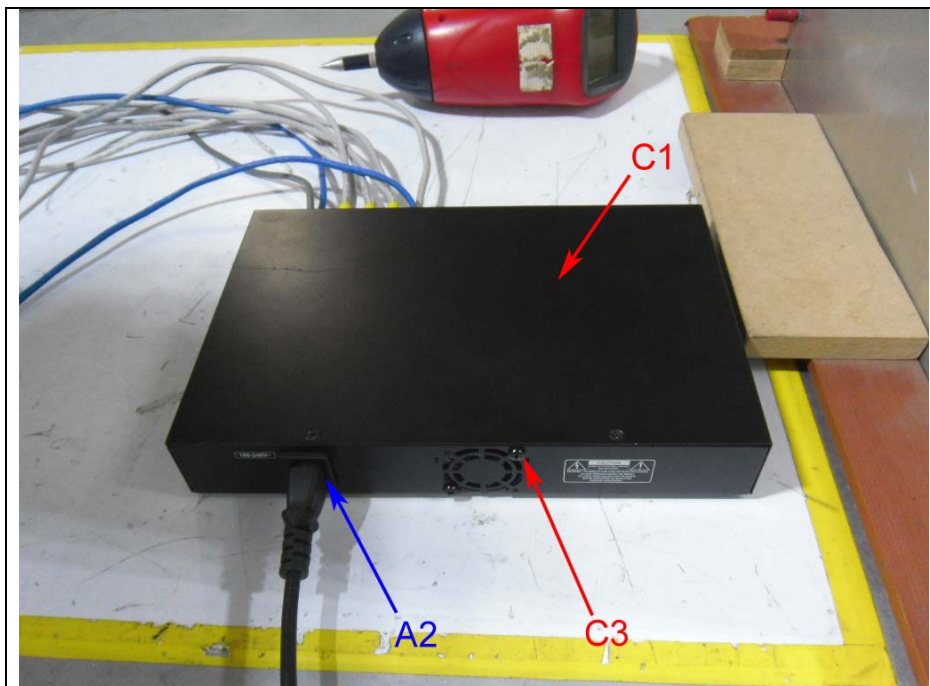
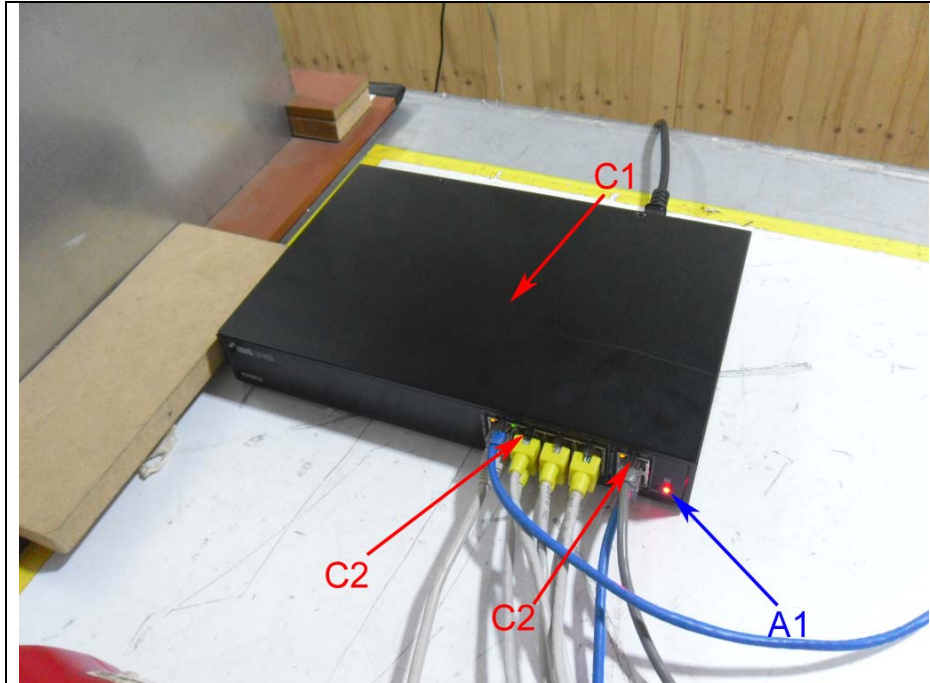

HCP/VCP discharge

Location(EUT)		Applied level (±)	Result (Criteria)
HCP (All 4 sides)		± 2 kV, ± 4 kV, ± 6 kV	A
VCP (All 4 sides)		± 2 kV, ± 4 kV, ± 6 kV	A

Contact discharge

Location(EUT)		Applied level (±)	Result (Criteria)
C1	Enclosure(Case)	± 6 kV	A
C2	RJ-45 Port	± 6 kV	A (*Note)See
C3	Screw	± 6 kV	A

Air discharge

Location(EUT)		Applied level (±)	Result (Criteria)
A1	LED	± 2 kV, ± 4 kV, ± 8 kV	A
A2	Power Port	± 2 kV, ± 4 kV, ± 8 kV	A

* Loss Chart (* Note: During the test, some packet was lost but link was alive. (C2: LAN Port))

	DOWN LINK TX	DOWN LINK RX	UP LINK TX	UP LINK RX	DOWN LOSS	UP LOSS	RESULT
ESD	101086660	101085131	1010866839	1010866784	1529	55	PASS

6.6 Radio Frequency Electromagnetic Fields

Test specification	ETSI EN 300 386 clause 7.2.2.1.2, Criteria : A				
Tested frequency	80 MHz ~ 800 MHz, 800 MHz ~ 960 MHz, 960 MHz ~ 1 GHz, 1.4 GHz ~ 2 GHz, 2 GHz ~ 2.7 GHz				
Test level & Modulation	80 MHz ~ 800 MHz: 3 V/m, 80 % Amplitude Modulation (1 kHz) 800 MHz ~ 960 MHz: 10 V/m, 80 % Amplitude Modulation (1 kHz) 960 MHz ~ 1 GHz: 3 V/m, 80 % Amplitude Modulation (1 kHz) 1.4 GHz ~ 2 GHz: 10 V/m, 80 % Amplitude Modulation (1 kHz) 2 GHz ~ 2.7 GHz: 3 V/m, 80 % Amplitude Modulation (1 kHz)				
Frequency Step	log 1 % step				
Dwell time	3 s				
Distance	3 m from EUT to tip of antenna				
Testing Voltage	230 V, 50 Hz				
Test facility	Fully anechoic chamber (3 m)				
Date	2014. 05. 08				
Temperature(°C)	24.3 °C	Humidity (% R.H.)	23.5 % R.H.	Pressure (kPa)	100.4 kPa
Remarks	Complied - A: There was no change of operation status during above testing.				

6.6.1 Measurement procedure

The test was performed at 3 m full anechoic chamber.

For floor standing equipment, the EUT was standing on the floor.

For tabletop equipment, the EUT was located on a wooden table 0.8 m above the floor.

The EUT was tested all sides, horizontal and vertical polarization.

6.6.2 Used equipments

Equipment	Model no.	Serial no.	Makers	Next Cal. date	Used
Power meter	PM2002	302852	AR	2015.02.07	<input checked="" type="checkbox"/>
Power sensor	PH2000	303224	AR	2015.02.07	<input checked="" type="checkbox"/>
Power sensor	PH2000	311217	AR	2015.02.07	<input checked="" type="checkbox"/>
Directional coupler	DC6180	303976	AR	2015.02.06	<input checked="" type="checkbox"/>
Directional coupler	DC7144M1	320279	AR	2015.02.06	<input checked="" type="checkbox"/>
Signal generator	E4421B	GB40052295	AGILENT	2015.02.06	<input checked="" type="checkbox"/>
Broadband Amplifier	BBA100	100996-1	R&S	2015.02.06	<input checked="" type="checkbox"/>
Amplifier	60S1G3M2	320444	AR	2015.04.02	<input checked="" type="checkbox"/>
Log Periodic Dipole Antenna	LPDA-0803	-	ETS	-	<input checked="" type="checkbox"/>
Isotropic Probe	HI-6105	156301	ETS-LINDGREN	2014.05.30	<input checked="" type="checkbox"/>
Antenna master	-	-	ETS	-	<input checked="" type="checkbox"/>

6.6.3 Photographs of test setup



6.6.4 Measurement result

Location(EUT)	Antenna polarization	Result (Criteria)
Front side	Horizontal	A
	Vertical	A
Rear side	Horizontal	A
	Vertical	A
Left side	Horizontal	A
	Vertical	A
Right side	Horizontal	A
	Vertical	A

* Loss Chart

RS	DOWN LINK TX	DOWN LINK RX	UP LINK TX	UP LINK RX	DOWN LOSS	UP LOSS	RESULT
30-1000M(3V/m)	679417856	679417517	6794178564	6794178343	339	221	PASS
800-960M(10V/m)	58894957	58894924	588949577	588949523	33	54	PASS
1.4-2G(10V/m)	53226084	53226061	53226084	53226037	23	47	PASS
2-2.7G(3V/m)	40342690	40342690	403426905	403426905	0	0	PASS

6.7 Electric Fast Transient/BURST

Test specification	ETSI EN 300 386 clause 7.2.2.4.1 / 7.2.2.2.1 / 7.2.2.3.1, Criteria : B				
Coupling	<input checked="" type="checkbox"/> AC main <input type="checkbox"/> Signal: Clamp <input checked="" type="checkbox"/> Telecommunication: Clamp				
Test level	<input checked="" type="checkbox"/> AC main: ± 1 kV Peak <input type="checkbox"/> Signal: ± 0.5 kV Peak <input checked="" type="checkbox"/> Telecommunication: ± 0.5 kV Peak				
Repetition frequency	5 kHz, Tr/Th = 5 / 50 ns				
Coupling time	60 s				
Testing Voltage	230 V, 50 Hz				
Test facility	Shielded room				
Date	2014. 05. 08				
Temperature(°C)	25.8 °C	Humidity (% R.H.)	36.3 % R.H.	Pressure (kPa)	100.6 kPa
Remarks	Complied - A: There was no change of operation status during above testing.				

6.7.1 Measurement procedure

A ground reference plane was located on the floor.

EFT generator was connected to reference ground plane via low impedance connection.

For floor standing equipment, EUT was placed on a 0.1 m wooden table.

For tabletop equipment, EUT was placed on a 0.1 m above the ground reference plane.

Test generator and coupling/decoupling network was placed on, and bounded to, the ground reference plane. When using the coupling clamp, the minimum distance between the coupling plates and all other conductive surfaces, except the ground reference plane beneath the coupling clamp, Shall be 0.5 m.

6.7.2 Used equipments

Equipment	Model No.	Serial No.	Makers	Next Cal. date	Used
Ultra compact simulator	UCS500N	V1238113636	EM TEST	2015.02.22	<input type="checkbox"/>
Ultra compact simulator	UCS500M	0701-03	EM TEST	2014.06.21	<input checked="" type="checkbox"/>
Capacitive Coupling Clamp	-	0001	EM TEST	2015.02.04	<input checked="" type="checkbox"/>

6.7.3 Photographs of test setup



6.7.4 Measurement result

* AC main

EFT coupling point	(+)	(-)	Result (Criteria)
L+N+PE	+ 1 kV	- 1 kV	A

* Signal

EFT coupling point	(+)	(-)	Result (Criteria)
-	-	-	-

* Telecommunication

EFT coupling point	(+)	(-)	Result (Criteria)
Cascade(RJ-45)	+ 0.5 kV	- 0.5 kV	A
PoE(RJ-45)	+ 0.5 kV	- 0.5 kV	A

* Loss Chart

	DOWN LINK TX	DOWN LINK RX	UP LINK TX	UP LINK RX	DOWN LOSS	UP LOSS	RESULT
BURST POWER	21475163	21452643	214751788	214672401	22520	79387	PASS
BURST UPLINK	21260112	21260109	212601097	212600773	3	324	PASS
BURST Downlink	26937887	26913418	212601137	212600273	24469	864	PASS

6.8 Surge

Test specification	ETSI EN 300 386 clause 7.2.2.4.2 / 7.2.2.2.2 / 7.2.2.3.2, Criteria : B				
Coupling	<input checked="" type="checkbox"/> AC main: Direct <input checked="" type="checkbox"/> Telecommunication: Direct, CDN				
Test level	<input checked="" type="checkbox"/> AC main: <input checked="" type="checkbox"/> Differential mode: ± 0.5 kV, ± 1 kV <input checked="" type="checkbox"/> Common mode: ± 0.5 kV, ± 1 kV, ± 2 kV <input checked="" type="checkbox"/> Telecommunication: ± 0.5 kV, ± 1 kV				
Coupling Impedance	<input checked="" type="checkbox"/> Differential mode: 18 μ F <input checked="" type="checkbox"/> Common mode: 10 Ω + 9 μ F <input checked="" type="checkbox"/> 40 Ω + 0.5 μ F <input checked="" type="checkbox"/> Direct				
Surge pulse shape	Tr/Th = 1.2 / 50 μ s (AC main/ Telecommunication_Cascade) Tr/Th = 10 / 700 μ s (Telecommunication_PoE)				
Angles	0 °, 90 °, 180 °, 270 °				
Number of surge	5				
Coupling time	1 min				
Testing Voltage	230 V, 50 Hz				
Test facility	Shielded room				
Date	2014. 05. 08				
Temperature(°C)	25.8 °C	Humidity (% R.H.)	36.3 % R.H.	Pressure (kPa)	100.6 kPa
Remarks	Complied - A: There was no change of operation status during above testing.				

6.8.1 Measurement procedure

A ground reference plane was located on the floor. SURGE generator was connected to reference ground plane via low impedance connection. For floor standing equipment & table top equipment, EUT was placed on a wooden table.

6.8.2 Used equipments

Equipment	Model No.	Serial No.	Makers	Next Cal. date	Used
Ultra compact simulator	UCS500N	V1238113636	EM TEST	2015.02.22	<input type="checkbox"/>
Ultra compact simulator	UCS500M	0701-03	EM TEST	2014.06.21	<input checked="" type="checkbox"/>
CDN	CNV 508 N1	V1108108861	EM TEST	2014.11.26	<input checked="" type="checkbox"/>
Surge generator	TSS 500	0402-01	EM TEST	2014.11.25	<input checked="" type="checkbox"/>

6.8.3 Photographs of test setup



(Indoor)



(Outdoor)



6.8.4 Measurement result

* AC main

Coupling point	(+)	(-)	Result (Criteria)
L+N	+ 0.5 kV, + 1 kV	- 0.5 kV, - 1 kV	A
L+PE	+ 0.5 kV, + 1 kV, + 2 kV	- 0.5 kV, - 1 kV, - 2 kV	A
N+PE	+ 0.5 kV, + 1 kV, + 2 kV	- 0.5 kV, - 1 kV, - 2 kV	A

* Telecommunication

Coupling point	(+)	(-)	Result (Criteria)
Cascade(RJ-45)	+ 0.5 kV	+ 0.5 kV	A
PoE(RJ-45)	+ 1 kV	+ 1 kV	A

* Loss Chart

	DOWN LINK TX	DOWN LINK RX	UP LINK TX	UP LINK RX	DOWN LOSS	UP LOSS	RESULT
SURGE POWER	679417856	679417835	6794181043	6794179236	21	1807	PASS
SURGE LINE	679417856	679417836	6794181043	6794181024	20	19	PASS

6.9 Conducted Immunity

Test specification	ETSI EN 300 386 clause 7.2.2.4.3/7.2.2.2.3/7.2.2.3.3, Criteria : A				
Tested frequency	0.15 MHz ~ 80 MHz				
Test level & Modulation	3 V, 80 % Amplitude Modulation (1 kHz)				
Frequency Step	log 1 % step				
Dwell time	3 s				
Coupling method	<input checked="" type="checkbox"/> AC main: CDN(M3) <input type="checkbox"/> Signal: Clamp <input checked="" type="checkbox"/> Telecommunication: CDN(T8-RJ-45)				
Testing Voltage	230 V, 50 Hz				
Test facility	Shielded room				
Date	2014. 05. 08				
Temperature(°C)	24.6 °C	Humidity (% R.H)	30.4 % R.H	Pressure(kPa)	100.3 kPa
Remarks	Complied - A: There was no change of operation status during above testing.				

6.9.1 Measurement procedure

A ground reference plane was located on the floor.

The test was performed on a ground reference plane on a 0.1 m wooden table. This test were Performed using CDN for mains, clamp for signal and injection probe. The frequency range was swept from 0.15 MHz to 80 MHz. This frequency range was Modulated with 1 kHz sine wave at 80 %.

The signal generators provided the modulated frequency at a 1 % step size.

The power and all network cable, I/O cables longer than 3 m length were tested.

6.9.2 Used equipments

Equipment	Model no.	Serial no.	Makers	Next Cal. date	Used
CS generator	NSG 2070	1054	Schaffner	2015.03.07	<input checked="" type="checkbox"/>
CDN	M016	16674	Schaffner	2015.03.07	<input checked="" type="checkbox"/>
CDN	CDN M2/M3N	0111-04	EM TEST	2015.01.29	<input type="checkbox"/>
Attenuator	INA2070-1	2054	Schaffner	2015.03.04	<input checked="" type="checkbox"/>
EM Clamp	KEMZ 801	17643	Schaffner	2015.05.08	<input type="checkbox"/>
CDN	CDN S1/75	0410-28	EM TEST	2015.04.16	<input type="checkbox"/>
CDN	CDN-T8-RJ45	0113-22	EM TEST	2015.01.29	<input checked="" type="checkbox"/>

6.9.3 Photographs of test setup

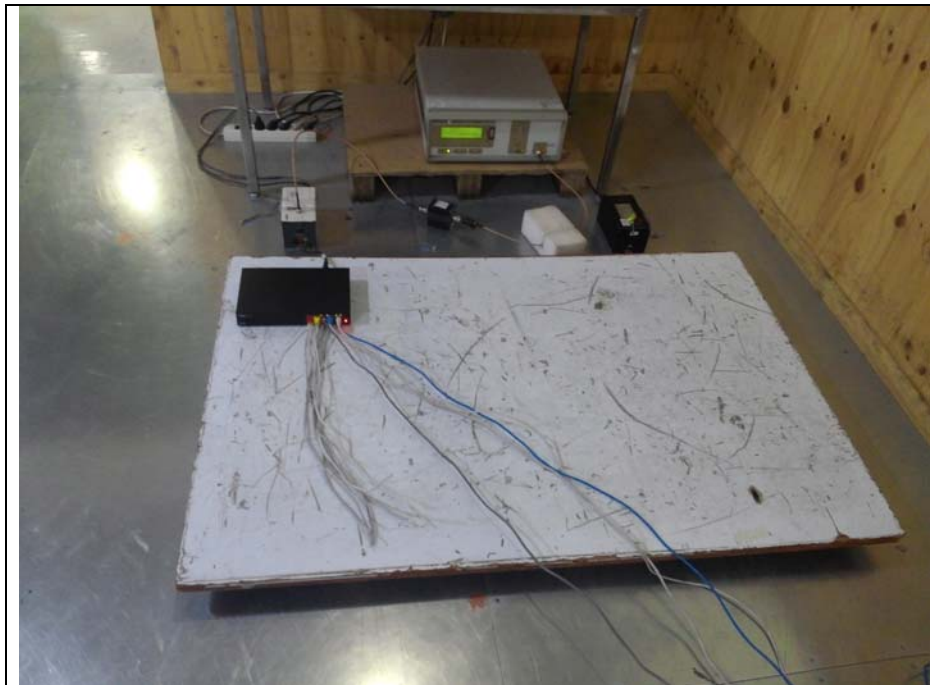

6.9.4 Measurement result

* AC main

Coupling point	Coupling method	Result (Criteria)
Power	CDN(M3)	A

* Signal

Coupling point	Coupling method	Result (Criteria)
-	-	-

* Telecommunication

Coupling point	Coupling method	Result (Criteria)
Cascade(RJ-45)	CDN(T8-RJ-45)	A
PoE(RJ-45)	CDN(T8-RJ-45)	A

* Loss Chart

	DOWN LINK TX	DOWN LINK RX	UP LINK TX	UP LINK RX	DOWN LOSS	UP LOSS	RESULT
CS POWER	103694029	103694029	1036940070	1036940070	0	0	PASS
CS UPLINK	108180044	108180044	1081800694	1081800694	0	0	PASS
CS Downlink	108180044	108180044	1081800694	1081800694	0	0	PASS

6.10 Dips and Interruptions

Test specification	ETSI EN 300 386 clause 7.2.2.4.4, Criteria : B or C				
Number of dips	3 T				
Duration	10 s				
Phase	Zero crossing (0 °, 180 °)				
Testing Voltage	240 V, 50 Hz / 100 V, 50 Hz				
Test facility	Shielded room				
Test Date	2014. 05. 08				
Temperature (°C)	25.8 °C	Humidity (% R.H.)	36.3 % R.H.	Pressure (kPa)	100.6 kPa
Remarks	Complied				

6.10.1 Measurement procedure

The dips/interruption test is only applicable to AC mains.

The dips/interruptions were applied at zero crossing.

6.10.2 Used equipments

Equipment	Model no.	Serial no.	Makers	Next Cal. date	Used
Ultra compact simulator	UCS500N	V1238113636	EM TEST	2015.02.22	<input type="checkbox"/>
Ultra compact simulator	UCS500M	0701-03	EM TEST	2014.06.21	<input checked="" type="checkbox"/>

6.10.3 Photographs of test setup

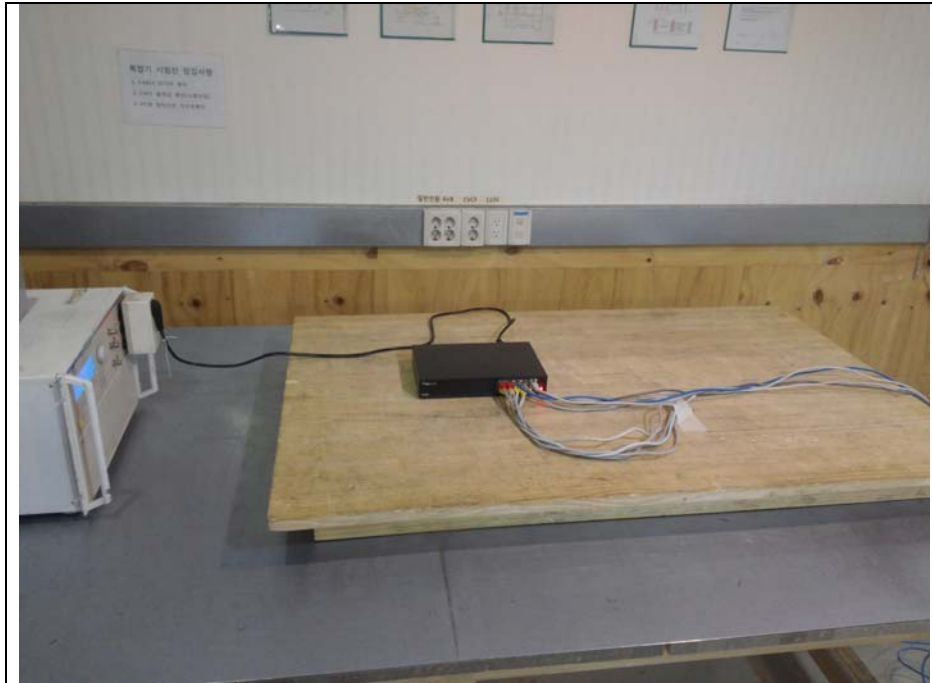

6.10.4 Measurement result

* 240 V, 50 Hz

Test Level (%UT)	Dip/Int. (%UT)	Duration /Period	Angle (°)	Count number	Result (Criterion)
0 %	100 %	0.5 Period	0 / 180	3T	A
0 %	100 %	1 Period	0	3T	A
70 %	30 %	25 Period	0	3T	A
0 %	100 %	250 Period	0	3T	C (*Note)See

Comment:

- A: There was no change of operation status during above testing. (0.5 Period, 1 Period, 25 Period)
- C: The power of EUT is off during the interruption test. After the test, EUT is getting back to normal operation. (250 Period)

* Loss Chart (*Note: During the test, some packet was lost but link was alive. (250 Period))

	DOWN LINK TX	DOWN LINK RX	UP LINK TX	UP LINK RX	DOWN LOSS	UP LOSS	RESULT
DIP	20171345	20171345	201713516	201713516	0	0	PASS
INT	7152338	3292406	35966524	17495292	3859932	18471232	PASS

* 100 V, 50 Hz

Test Level (%UT)	Dip/Int. (%UT)	Duration /Period	Angle (°)	Count number	Result (Criterion)
0 %	100 %	0.5 Period	0 / 180	3T	A
0 %	100 %	1 Period	0	3T	A
70 %	30 %	25 Period	0	3T	A
0 %	100 %	250 Period	0	3T	C (*Note)See

Comment:

- A: There was no change of operation status during above testing. (0.5 Period, 1 Period, 25 Period)
- C: The power of EUT is off during the interruption test. After the test, EUT is getting back to normal operation. (250 Period)

* Loss Chart (*Note: During the test, some packet was lost but link was alive. (250 Period))

	DOWN LINK TX	DOWN LINK RX	UP LINK TX	UP LINK RX	DOWN LOSS	UP LOSS	RESULT
DIP	20171345	20171345	201713516	201713516	0	0	PASS
INT	7152338	3292406	35966524	17495292	3859932	18471232	PASS

7. E.U.T. photographs

Front View



Rear View



Left View



Right View



Top View

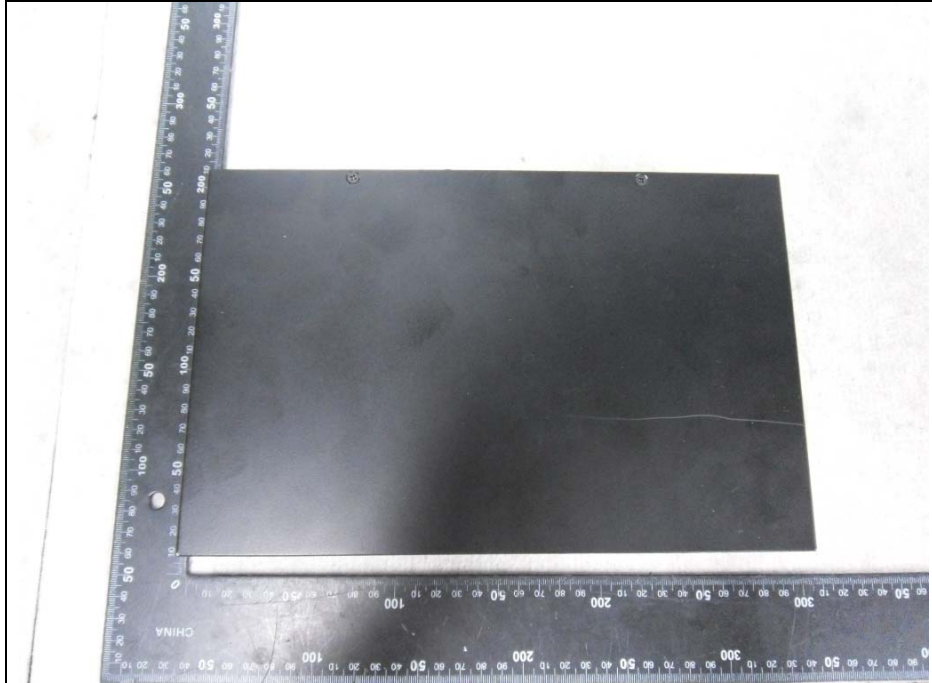

Bottom View



Inside



Main Board

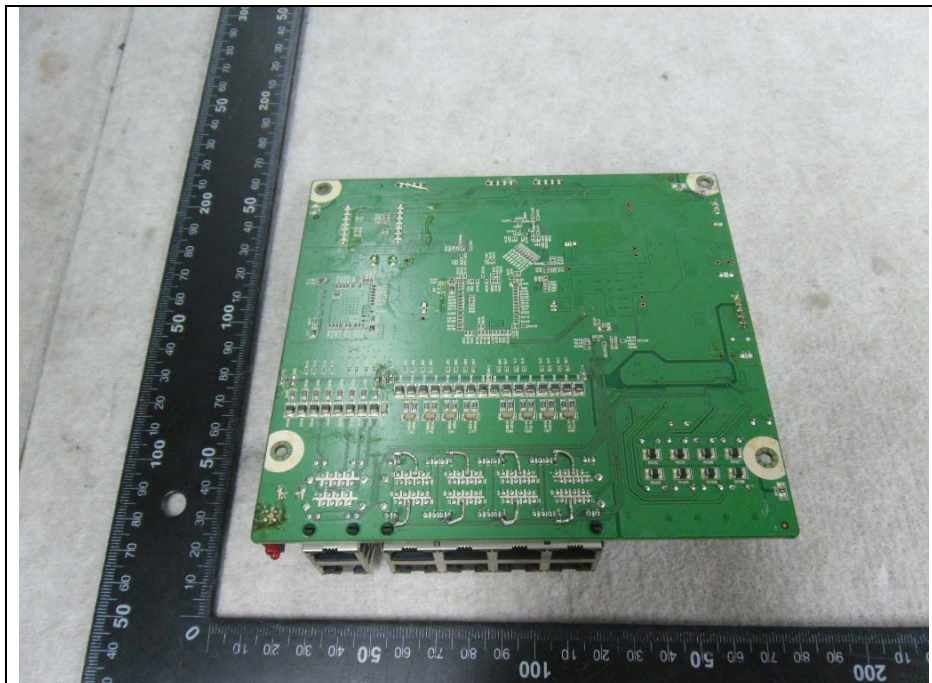

Power Board

